

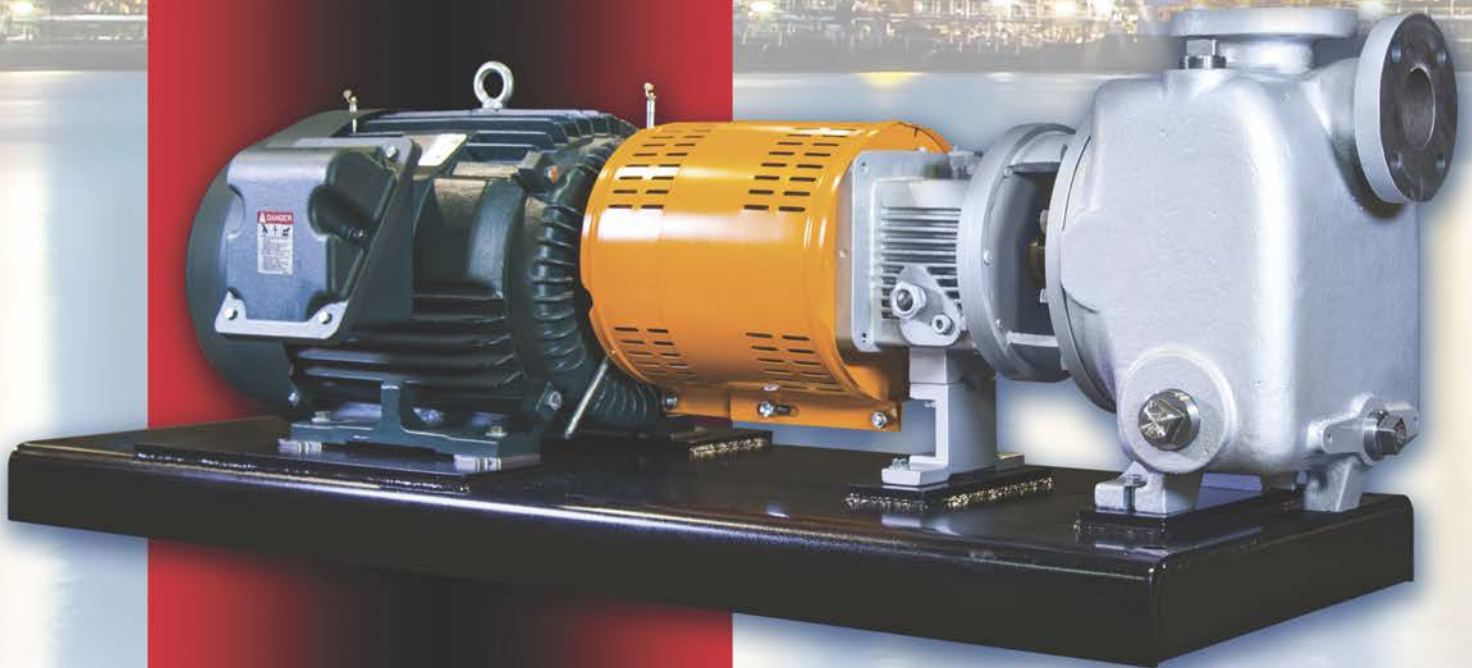

PWA-SP

**SELF PRIMING
PROCESS PUMP**



Dynapumps®
BUILDING FOR LIFE

PWA-SP SELF-PRIMING PROCESS PUMP

COMPETITIVE ADVANTAGES

Carbon Steel vs. Ductile Iron

- High strength, impact resistant Carbon Steel liquid ends for improved durability and pressure containment at no additional cost.
- Replaces non-repairable, ductile iron casing and impellers, with repairable carbon steel, for extended component life.

Flange Arrangement Options

- Standard ANSI class 150# flange pressure rating, flat or raised face design, provided to meet customer specified requirements at no additional cost.



Shaft and Bearing Assembly

- Upgraded 316 SS vs. 4140 steel pump shaft is standard at no additional cost.
- Proven flinger disk lubrication device to ensure effective bearing lubrication. Provides 30% increased bearing L-10 life and minimum 15° lower bearing operating temperatures compared to flood oil design.

Casing

- High strength Carbon Steel casing, resistant to rupture due to retained priming fluid during freezing temperature conditions.
- Self venting, centerline discharge, back pull out design.
- Air separators, valves or special priming chambers not required.
- Standard 150# FF and 150# RF optional flange connections.



5 Year Unconditional Power Frame Warranty is Standard at No Additional Cost.

Power Frame Superiority

- Superior high strength carbon steel vs. inferior cast iron power frame material.
- Addresses environmental and safety concerns.
- Exclusive finned bearing frame for maximum heat dissipation.
- Convenient dual oil level sight glasses provide flexible viewing as standard.



Standard bore



Tapered bore



Big bore



Component seal



Single cartridge seal



Dual cartridge seal

Seal Chamber / Sealing Solutions

- Multiple seal chambers for maximum sealing flexibility for all process applications.
- Seal chambers machined from billeted, high quality bar stock with exceptionally smooth stuffing box finish and customizable flush locations, if required.
- Accommodates all mechanical seal manufacturer's component and ANSI cartridge seal configurations.
- Supports the full array of CPI seal support system options.
- Ensures superior leak protection with maximum heat dissipation, maximizing seal life and pump reliability.

All materials are USA sourced to meet all Country of Origin requirements.

PWA-SP SELF-PRIMING PROCESS PUMP

LEVERAGING TECHNOLOGY

PumpWorks Industrial leverages technology by providing:

- Superior manufacturing capabilities.
- Extensive inventory selection.
- Professional, reliable service.
- Fully ISO 9001 certified.



FOUNDRY PumpWorks Castings

- Precision investment cast impellers yields exceptionally smooth surface finish ensuring repeatable, efficient hydraulic performance.
- One ton piece part capacity. Metallurgies from Carbon Steel through Titanium.
- Complete in house casting inspection includes certified spectrographic, hardness, physical properties and live casting X-ray analysis.



MANUFACTURING

- All of our pumps are manufactured and tested in the United States of America, utilizing exclusive state-of-the-art manufacturing equipment and US foundries for all castings. This ensures consistent quality, product availability, and low cost of ownership.

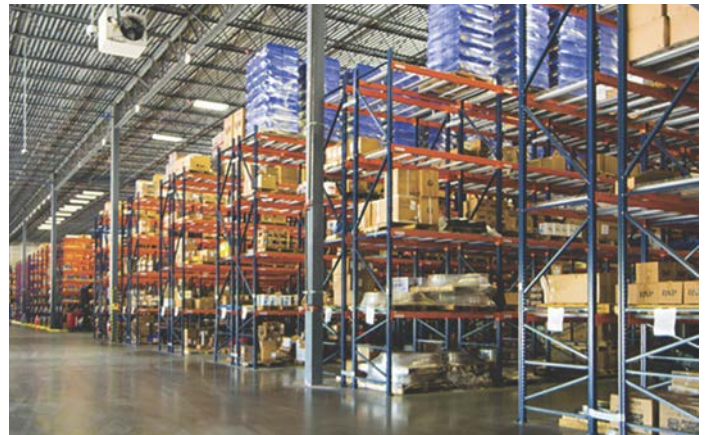

INVENTORY

- Pump and component inventory in a variety of material options are strategically located through the Northern hemisphere ensuring consistent, rapid shipment tailored to customer requirements.

SERVICE

- Fully staffed professional sales and service teams providing superior customer support is available 24/7/365.



PWA-SP SELF-PRIMING PROCESS PUMP

DESIGN FEATURES AND BENEFITS

● Casing Gasket

- Fully confined to maximize liquid sealing
- Protects casing fits from corrosion, therefore increase maintenance ease and proper alignment during reassembly

● Seal Chamber / Sealing Options

- Multiple seal chambers for maximum sealing flexibility for all process applications.
- Accommodates all mechanical seal manufacturer's component and ANSI cartridge seal configurations
- Supports the full array of CPI seal support system options
- Ensures superior leak protection with maximum heat dissipation, maximizing seal life and pump reliability.

● Casing

- Self venting, centerline discharge back pull out design
- High strength Carbon Steel casing, resistance to rupture due to retained priming fluid during ambient freezing temperatures
- Air separators, valves or special priming chambers not required
- Standard 150# FF and 150# RF optional flange connections

● Quality

- Manufactured and tested in the USA

● Impeller

- Fully open for increased corrosion, abrasion and solids wear resistance
- Back pump out vanes for reduced thrust loading and seal chamber operating pressure

● Delivery

- Pump components strategically inventoried for rapid shipment in a variety of material options.

● Casing Drain

- Optional casing drain and drain piping

● Foot Mounted Casing

- Maximum casing stability and support for back pull out maintenance feature
- Reduced vibration

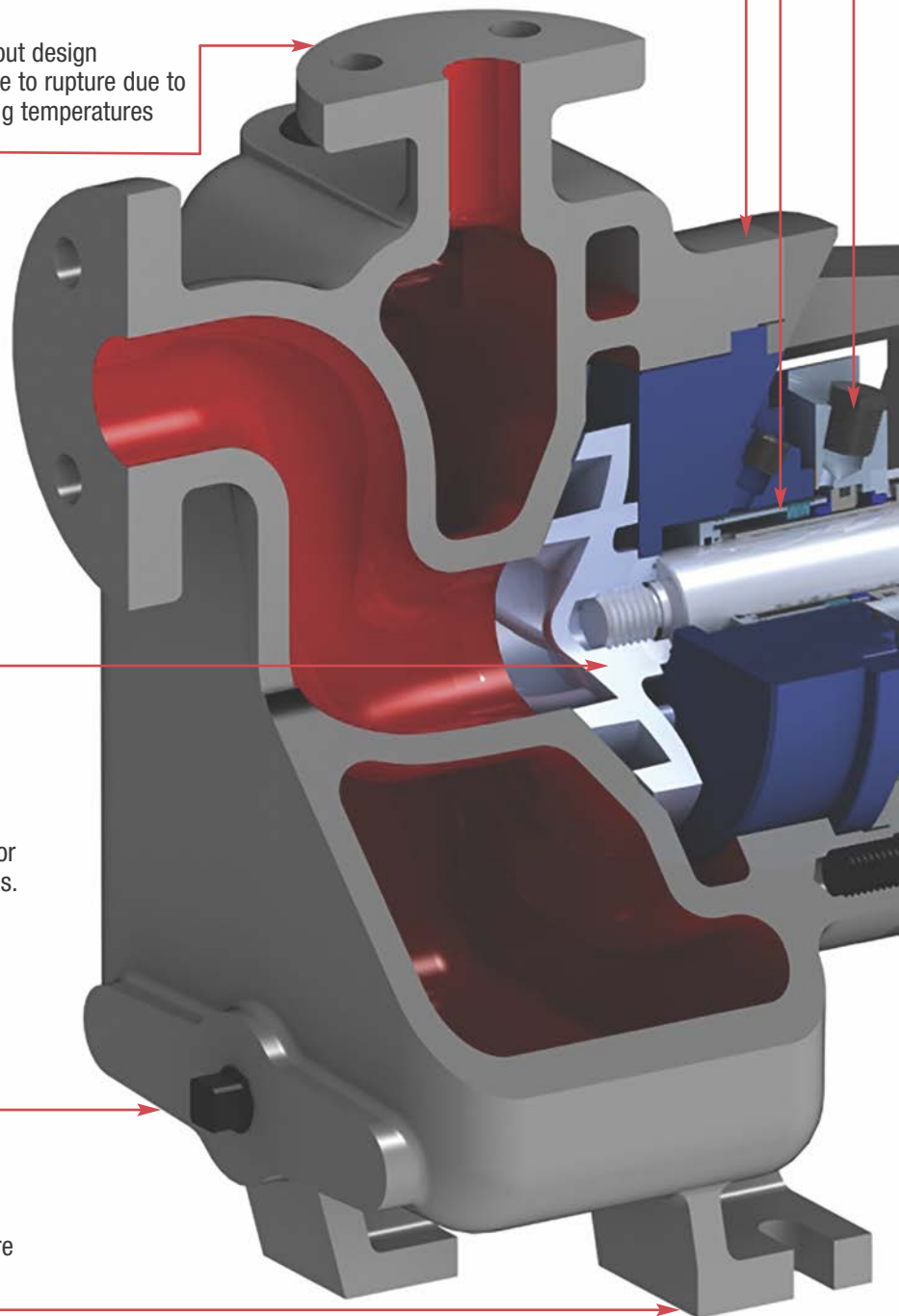

ePOD Pump Selector

- Access to end users and specifiers to select your pump application online at www.pumpworksindustrial.com

Frame Adapter

- Carbon Steel standard for increased strength and stability

Bearing Lubrication

- Flinger disk lubrication device to ensure effective bearing lubrication and lower bearing operating temperatures

Filter Vent

- Allows free exchange of clean, dry filtered air within the bearing housing protecting oil and bearings from moisture and particle contamination

Labyrinth Oil Seal

- Inpro VBXX-D bearing housing isolators providing positive sealing environment preventing oil contamination
- Optional Sealed bearing frame with magnetic seals and expansion chamber for severe environments

Thrust Bearing

- Heavy duty double row standard
- Optional duplex angular contact thrust bearing

Externally Adjustable Shaft and Impeller System

- Easily adjust impeller to front casing clearance without removal of pump from piping
- Restoration to factory efficiencies

Bearing Housing

- Large oil sump capacity for increased cooling
- Standard Splash Oil design, with optional regreasable, purge oil mist and pure oil mist lubrication
- Standard finned design for maximum heat dissipation
- Contoured internal slope for positive collection of metal contaminants by magnetic drain plug
- Optional 316 SS Tube Finned Cooler for high process temperatures above 350° F to 500° F

Two Oil Level Sight Glasses

- 1" sight glass located on each side of bearing housing for flexible viewing

Oil Sump Drain Plug

- Magnetic plug to maintain bearing housing cleanliness and increased protection

Shaft and Bearing System

- Rigid, heavy duty design for minimal shaft deflection at seal area and increased reliability
- Exceeds ASME B73.1 bearing life specification requirements
- 316L Shaft material is standard with optional material upgrades available

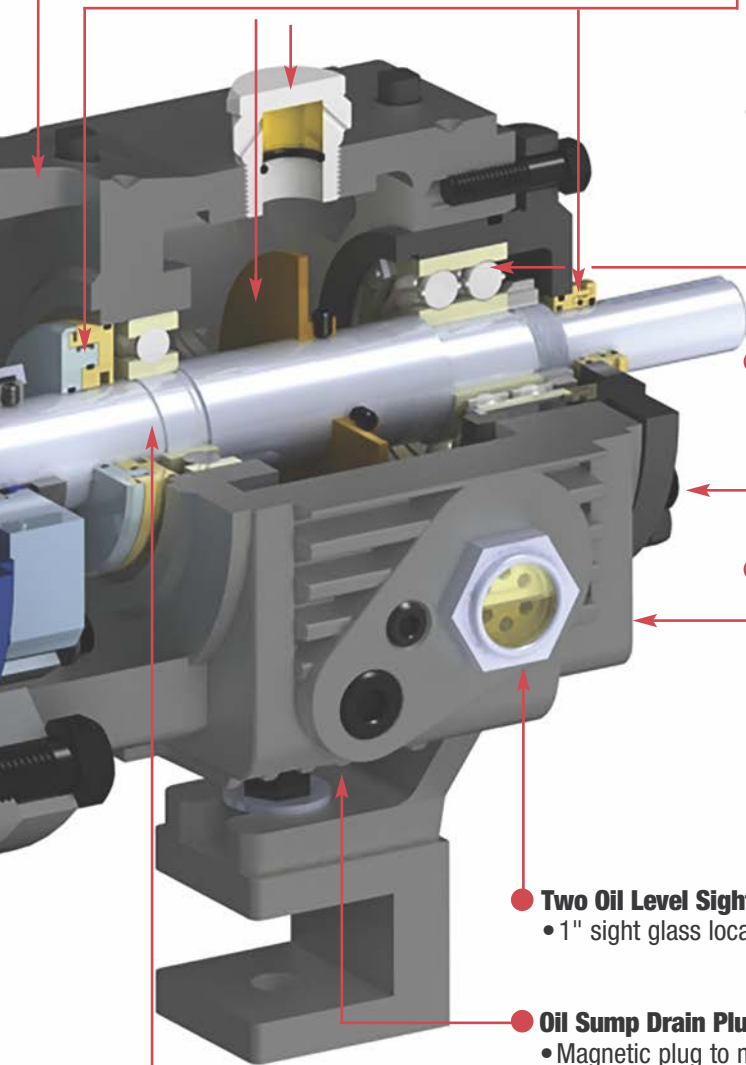

PWA-SP SELF-PRIMING PROCESS PUMP

HYDRAULIC PERFORMANCE COVERAGE

50 Hz Performance Coverage

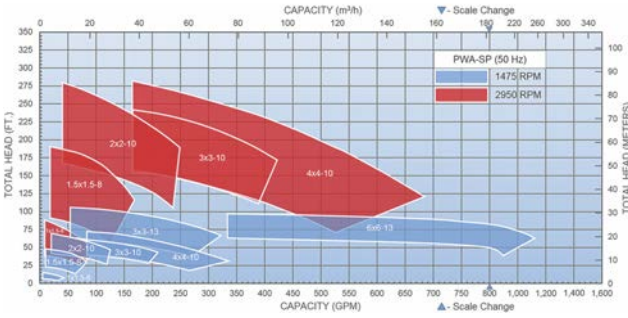

Visit our web site at www.pumpworksindustrial.com and specify flow and performance needs and obtain pump selection, performance curve, drawing, and data sheet.



Performances shown are nominal and are to be used for preliminary selection only.

60 Hz Performance Coverage

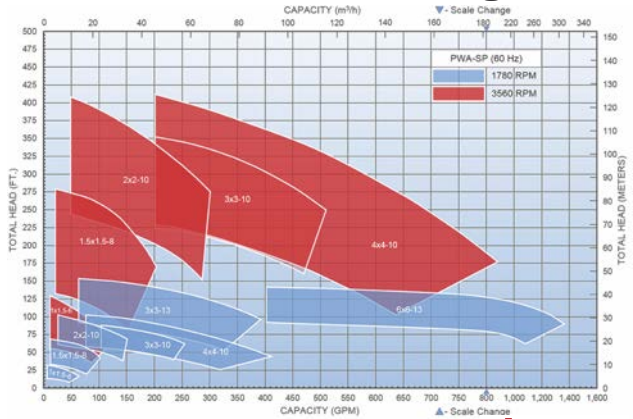

Visit our web site at www.pumpworksindustrial.com and specify flow and performance needs and obtain pump selection, performance curve, drawing, and data sheet.



Performances shown are nominal and are to be used for preliminary selection only.

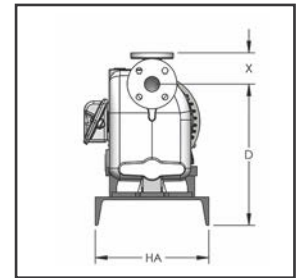
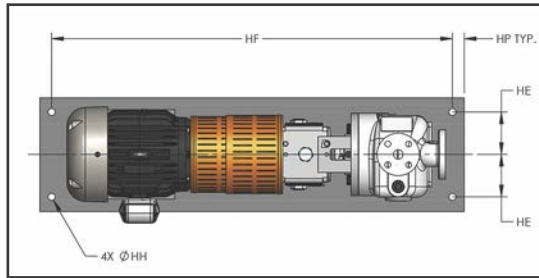
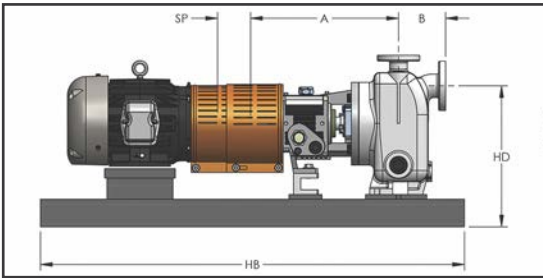

Not to be used for construction unless certified by manufacturer.

PUMP DIMENSIONS AND WEIGHTS

POWER FRAME	SIZE	DISCHARGE	SUCTION	X	A	B	D	E	SP	WEIGHT BARE PUMP lb (kg)	NEMA MOTOR FRAME	WEIGHT lb (kg)
GROUP 1	1X1.5X6	1	1.5	7.25 (184)	15.5 (394)	5.0 (127)	7.5 (191)	4.0 (102)	3.75 (95)	170 (77)	184T	128 (58)
	1.5X1.5X8	1.5	1.5	7.875 (200)	15.5 (394)	5.0 (127)	7.5 (191)	4.0 (102)	3.75 (95)	170 (77)	213T	197 (89)
GROUP 2	2X2X10	2	2	10 (254)	21.75 (552)	6.5 (165)	10 (254)	6.0 (152)	3.75 (95)	270 (123)	215T	226 (103)
	3X3X10	3	3	10 (254)	22.625 (575)	6.75 (171)	10 (254)	6.0 (152)	3.75 (95)	315 (143)	254T	375 (170)
	4X4X10	4	4	10 (254)	23.375 (594)	9.1875 (233)	10 (254)	6.0 (152)	3.75 (95)	370 (168)	256T	412 (187)
	3X3X13	3	3	11.5 (292)	22.625 (575)	6.75 (171)	10 (254)	6.0 (152)	3.75 (95)	400 (182)	284T	495 (225)
	4X4X13	4	4	11.5 (292)	23.375 (594)	9.1875 (233)	10 (254)	6.0 (152)	3.75 (95)	470 (214)	286T	519 (235)
	6X6X13	6	6	15 (356)	15.25 (387)	10 (254)	12 (356)	8.0 (203)	3.75 (95)	690 (314)	324T	700 (318)
GROUP 3	2X2X10	2	2	10 (254)	21.75 (552)	6.5 (165)	10 (254)	6.0 (152)	3.75 (95)	280 (128)	326T	756 (343)
	3X3X10	3	3	10 (254)	22.625 (575)	6.75 (171)	10 (254)	6.0 (152)	3.75 (95)	325 (146)	364T	948 (430)
	4X4X10	4	4	10 (254)	23.375 (594)	9.1875 (233)	10 (254)	6.0 (152)	3.75 (95)	380 (175)	365T	1009 (458)
	3X3X13	3	3	11.5 (292)	22.625 (575)	6.75 (171)	10 (254)	6.0 (152)	3.75 (95)	410 (189)	405T	1330 (603)
	4X4X13	4	4	11.5 (292)	23.375 (594)	9.1875 (233)	10 (254)	6.0 (152)	3.75 (95)	480 (221)	444T	1820 (826)
	6X6X13	6	6	15 (356)	15.25 (387)	10 (254)	12 (356)	8.0 (203)	3.75 (95)	700 (322)		

Weights and dimensions are approximate and not to be used for construction.

BASEPLATE DIMENSIONS AND WEIGHTS

MAX NEMA FRAME	HA Max	HB	HD Max			HE	HF	HH	HP TYP	WEIGHT lb (kg)
			D=7.5 (191)	D=10 (254)	D=12 (359)					
184T	15 (381)	39 (991)	9 (229)			4.5 (114)	36.5 (927)	0.75 (19)	1.25 (32)	199 (90)
M 324T	18 (457)	48 (1219)	10.5 (267)			6 (152)	45.5 (1156)	0.75 (19)	1.25 (32)	258 (117)
184T	15 (381)	45 (1143)		13.75 (349)		4.5 (114)	42.5 (1080)	0.75 (19)	1.25 (32)	266 (121)
215T	18 (457)	52 (1321)		14.13 (359)		6 (152)	49.5 (1257)	0.75 (19)	1.25 (32)	305 (138)
286T	21 (533)	58 (1473)		14.75 (375)		7.5 (191)	55.5 (1410)	1 (25)	1.25 (32)	323 (147)
365T	21 (533)	64 (1626)		14.75 (375)		7.5 (191)	61.5 (1562)	1 (25)	1.25 (32)	346 (157)
405TS	26 (660)	68 (1727)		14.88 (378)		9.5 (241)	65.5 (1664)	1 (25)	1.25 (32)	372 (169)
286T	26 (660)	68 (1727)			19.25 (489)	9.5 (241)	65.5 (1664)	1 (25)	1.25 (32)	493 (224)
405T	26 (660)	80 (2032)			19.25 (489)	9.5 (241)	77.5 (1969)	1 (25)	1.25 (32)	580 (263)
449T	26 (660)	98 (2489)			19.25 (489)	9.5 (241)	95.5 (2426)	1 (25)	1.25 (32)	710 (322)

Weights and dimensions are approximate and not to be used for construction.

PWA-SP SELF-PRIMING PROCESS PUMP

PARTS LIST AND MATERIALS OF CONSTRUCTION

Item Ref Number	Part Name	Carbon Steel	Carbon Steel w 316 SS Impeller	316SS	Super Duplex SS	Alloy 20	Hastelloy B & C	Titanium	
100	Casing	Carbon Steel	Carbon steel	316SS	Super Duplex SS CD4 Gr5A	Alloy 20	Hastelloy B & C	Titanium	
101	Impeller	Carbon Steel	316SS	316SS	Super Duplex SS CD4 Gr5A	Alloy 20	Hastelloy B & C	Titanium	
105	Lantern Ring	Glass Filled Teflon							
106	Packing, Stuffing Box	Teflon - Impregnated Fibers							
108	Adapter, Frame	Carbon Steel							
112A	Thrust Bearing	Double Row Angular Contact ⁽¹⁾							
122	Shaft - Less Sleeve	316L (Optional-Alloy 20 & A2205)				Alloy 20	Hastelloy B & C	Titanium	
122	Shaft with Sleeve	316L (Optional-Alloy 20 & A2205)							
126	Shaft Sleeve	316SS (Optional-Alloy 20 & A2205)			Super Duplex SS CD4 Gr5A		Alloy 20	Hastelloy B & C	Titanium
136	Bearing Lock Nut and Lock Washer	Steel							
168A	Radial Bearing	Single Row Deep Groove							
184	Cover, Stuffing Box (Packed Box)	Carbon Steel	Carbon Steel	316SS	Super Duplex SS CD4 Gr5A	Alloy 20	Hastelloy B & C	Titanium	
184	Seal Chamber (Mechanical Seal)	Carbon Steel	Carbon Steel	316SS	Super Duplex SS CD4 Gr5A	Alloy 20	Hastelloy B & C	Titanium	
228	Frame, Bearing	Carbon Steel							
248A	Flinger with set screw	Bronze with steel set screw							
250	Gland - Seal/Packing	316SS			Super Duplex SS CD4 Gr5A		Alloy 20	Hastelloy B & C	Titanium
370H	Stud/Nut, Cover to Adapter	304SS							
319	Sight Glass - Oil	Glass/Steel							
332A	INPRO-Oil Seal (Outboard)	Bronze							
333A	INPRO-Oil Seal (Inboard)	Stainless Steel/Bronze							
351	Gasket, Casing	Aramid Fiber with Binder							
358	Plug, Casing Drain (Optional)	Carbon Steel	Carbon Steel	316SS	Super Duplex SS CD4 Gr5A	Alloy 20	Hastelloy B & C	Titanium	
360F	Gasket, Frame to Adapter	Buna Rubber							
360C	Gasket, Bearing End Cover	Cellulose Fiber with Binder							
370	Cap Screw, Adapter to Casing	Steel							
412A	O-ring, Impeller	Glass Filled Teflon							
418	Jacking Bolt	304SS							
469B	Dowel Pin, Frame to Adapter	Steel							
496	O-ring, Bearing Housing	Buna Rubber							
637	Filter Vent	Carbon Steel							

(1) Duplex angular contact bearing Standard on Group 3, Bearing Frame and optional on Group 1 and 2.

GROUP 1 Sectional View PWA-SP

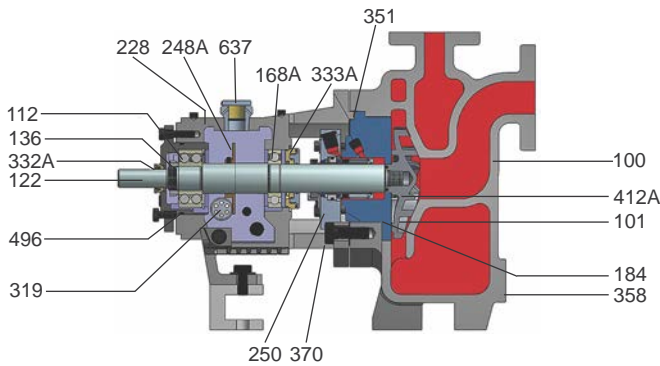

GROUP 2 / GROUP 3 Sectional View PWA-SP

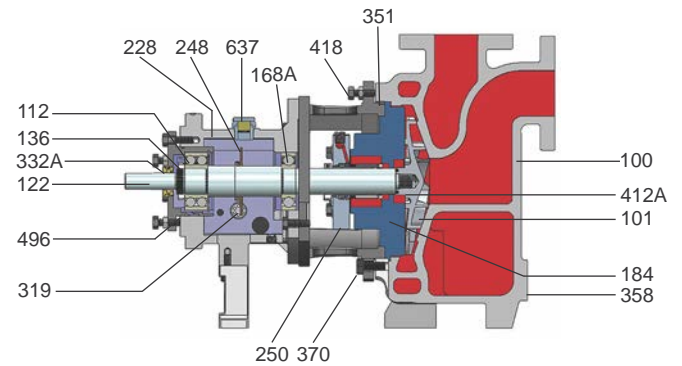

PWA-SP SELF-PRIMING PROCESS PUMP

TECHNICAL DATA All dimensions in inches and (mm)

		GP1	GP2	GP3
Shaft	Shaft Diameter at Impeller	0.75 (19)	1 (25)	1.25 (32)
	Diameter in Stuffing Box/Seal Chamber			
	(Less sleeve)	1.375 (35)	1.75 (45)	2.125 (54)
	(With sleeve)	1.125 (29)	1.5 (38)	1.875 (48)
	Diameter Between Bearings	1.5 (38)	2.125 (54)	2.5 (64)
	Diameter at Coupling	0.875 (22)	1.125 (29)	1.875 (48)
	Overhang	6.125 (156)	8.375 (213)	8.375 (213)
	Maximum Shaft Deflection	0.002 (0.05)		
	Shaft Deflection Index (L^3/D^4)			
	(Less sleeve)	64	63	48
(With sleeve)	143	116	29	
Sleeve	Outside Diameter thru Stuffing Box/Seal Chamber	1.375 (35)	1.75 (45)	2.125 (54)
Bearings	Radial	6207	6309	6311
	Thrust	3306	3309	7310
	Bearing Span	4.125 (105)	6.75 (171)	6.875 (164)
Large Bore Seal Chamber	Bore	2.875 (73)	3.5 (89)	3.875 (98)
Stuffing Box	Bore	2 (51)	2.5 (64)	2.875 (73)
Maximum Power Limits	HP (kW) per 100 RPM	1.1 (0.82)	3.4 (2.6)	5.6 (4.2)
Maximum Allowable Working Pressure	MAWP PSI (kPa)*	up to 280 PSI (1931 kPa) at 100° F with 150# flanges – consult factory for higher pressure requirements		
		*Consult Pressure Temperature chart for various temperatures		
Maximum Temperature	Oil or Grease Lubricated Bearing Frame without Optional Cooling	350° F (177°C)		
	Oil Lubricated Power Frame with Tube Finned Cooler	500° F (260°C)		
Casing	Corrosion Allowance	0.125 (3) minimum		

Hydro-static test pressure equal to 1.5 times Maximum Allowable Working Pressure

Test Facilities

- Test flows up to 7,500 GPM.
- Discharge test pressures up to 740 PSI.
- Supply tank rated from full vacuum to 65 psi.
- 460 volt through 500 HP, 3600 RPM.
- Variable Frequency Drive for precise speed control through 500 HP @ 460 volt.



Typical Industries

- Chemical/Petrochemical
- Pulp and Paper
- Food and Beverage
- Oil and Gas
- Primary Metals Manufacturing
- Mining
- Power Generation
- Waste Treatment
- General Industrial

For more information and to request a quote contact one of the Dynapumps offices Australia-wide

Phone 1300 788 579
sales@dynapumps.com.au
www.dynapumps.com.au

Perth - Head Office
88 Belgravia Street,
Belmont, WA 6104
(08) 9424 2000

Brisbane
Unit 7/ 14 Hopper Ave
Ormeau, QLD 4208
(07) 5546 7777

Sales & Service Centre
Unit 3, 94 Belgravia Street,
Belmont WA 6104
(08) 9424 2000

Sydney
Unit 5 / 6 Stanton Road,
Seven Hills, NSW 2147
(02) 9624 7888

Melbourne
Unit 5/39 Heyington Ave
Thomastown, VIC 3074
(03) 9464 3039