

NG

ISO 2858

NORM PUMPS



Handled Liquids

Clean or normal contaminated low or medium viscosity liquids without solid & fibrous particles.

Technical Data

Discharge Flange _____ DN 32.....DN 250 mm

Capacity _____ up to 1500 m³/h

Head _____ up to 160 m

Speed _____ up to 2900 rpm

Operating Temperature _____ -10 °C' to +175 °C (*)

Casing Pressure (Pmax) _____ 16 bar (25 bar) (*)

(Pmax: Suction Pressure + Shut off Head)

(*) The Material of pumps differ according to the type of pumped liquid, operating temperature and pressure. Contact for detailed information.

Design Features

- Horizontal, radially split volute casing type, single stage, end suction centrifugal pumps with closed or semi-open impeller.
- In addition to 28 basic sizes conforming with ISO 2858, there are 10 additional sizes. Dimensions of additional sizes may differ from other suppliers.
- Heavy duty shaft not in contact with the medium handled (dry shaft)

Pump Designation

Pump Type _____

Discharge Nozzle (DN-mm) _____

Nominal Impeller Diameter(mm) _____

Impeller Type (A: semi-open) _____

- For casing sealing, confined gaskets are used to prevent blow-out under pressure.
- Suction and discharge flanges conform to EN 1092-2 / PN 16. (EN 1092-1 / PN 16 for steel or stainless steel casing)
- Due to the back-pull-out design, the complete bearing assembly including impeller and casing cover can be dismantled without removing the volute casing from the pipe system. (With spacer coupling application, also possible to take out the rotor group without dismantling the electric motor.)
- All impellers are balanced dynamically or statically according to ISO 1940 class 6.3.
- For closed impellers, axial thrust is balanced by impeller balancing holes system while for semi-open impellers, it is balanced by back ribs.
- Direction of rotation is clockwise viewed from drive end.
- Bearings of NG type pumps are always oil lubricated.

Shaft Sealing

- Depending on request or requirement, pumps with soft packing or single, double and cartridge type mechanical seals can be supplied.
- External seal cooling system may be used if required.

NG 100-250-A

Field Charts

1450 rpm

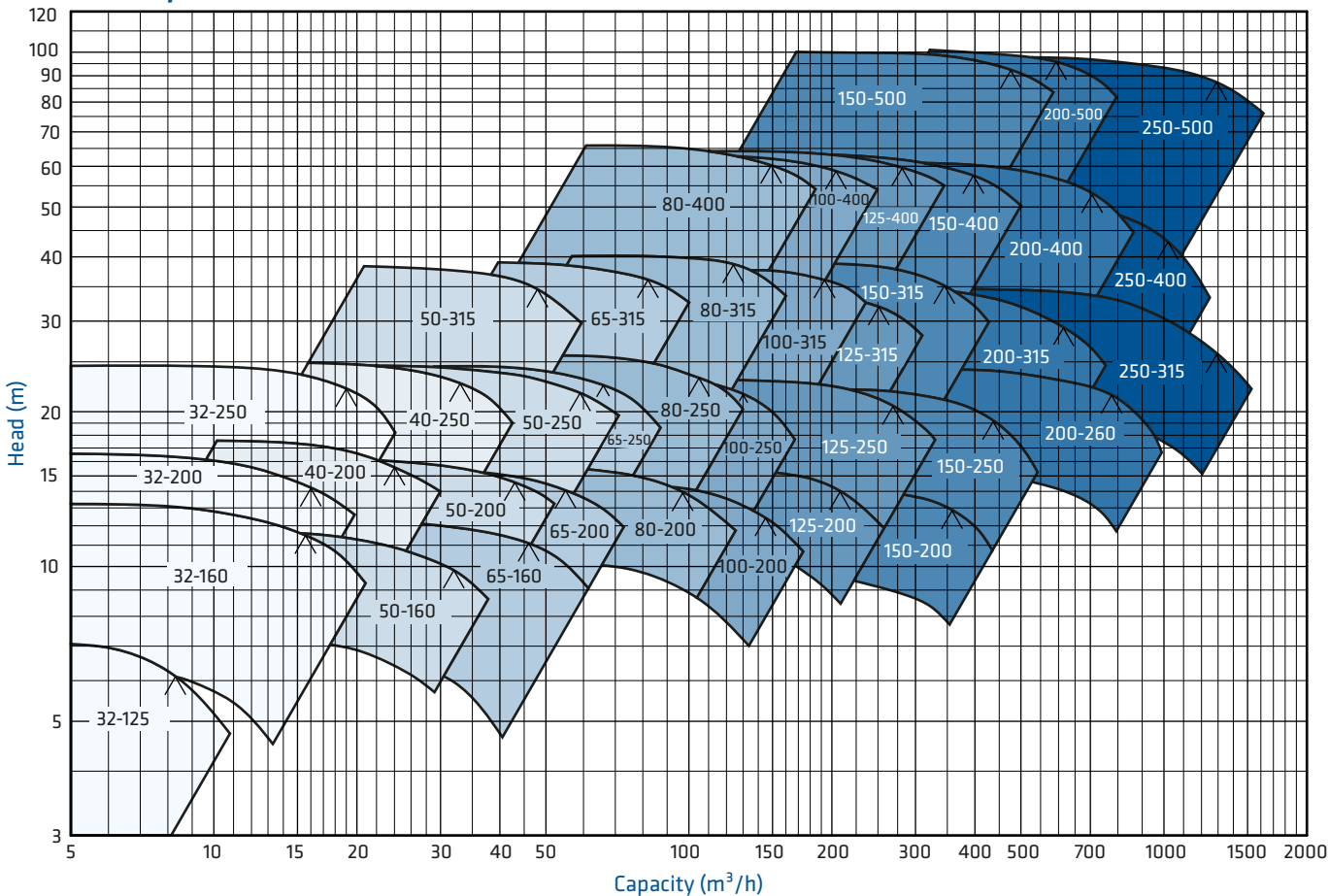

2900 rpm

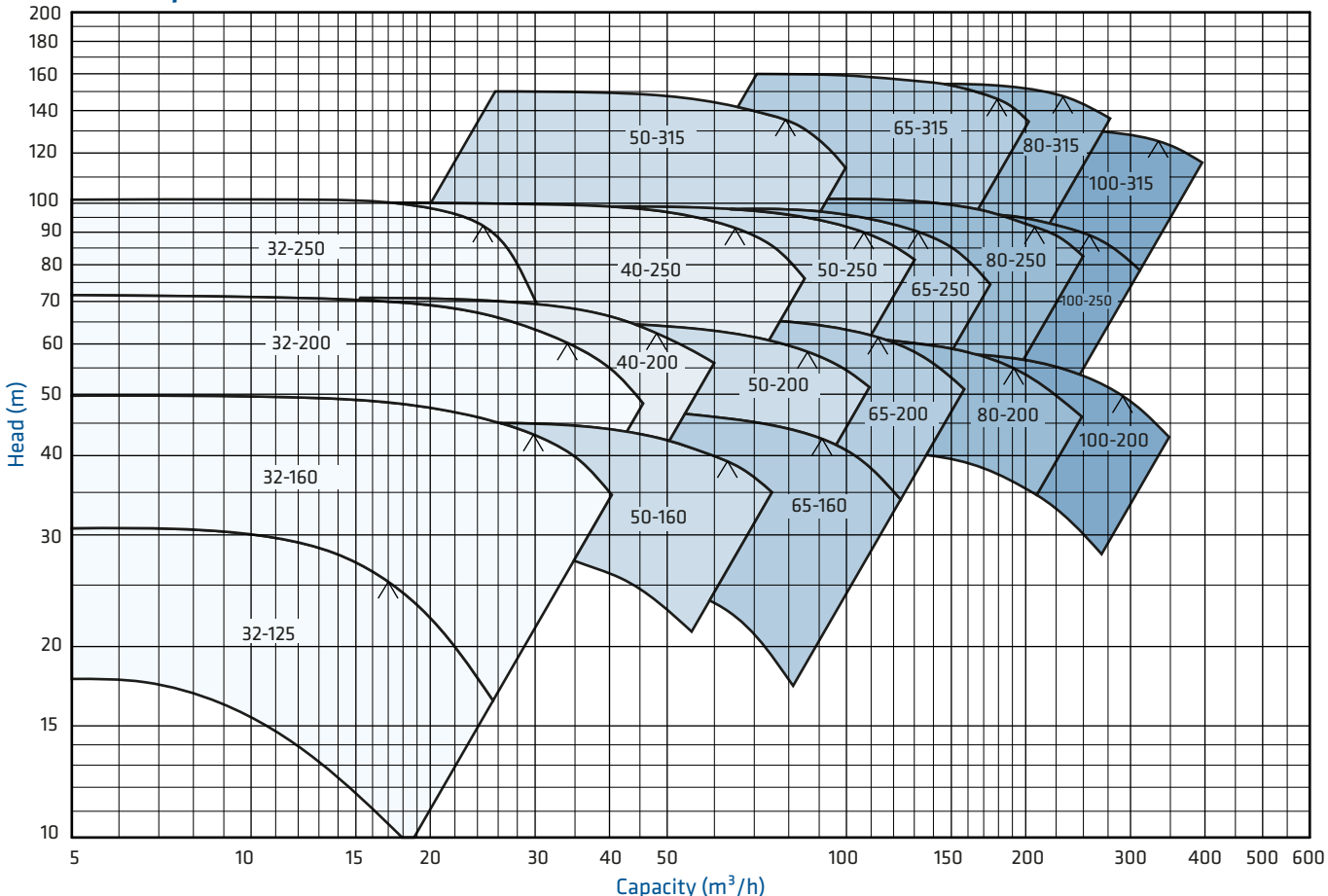

Technical Data

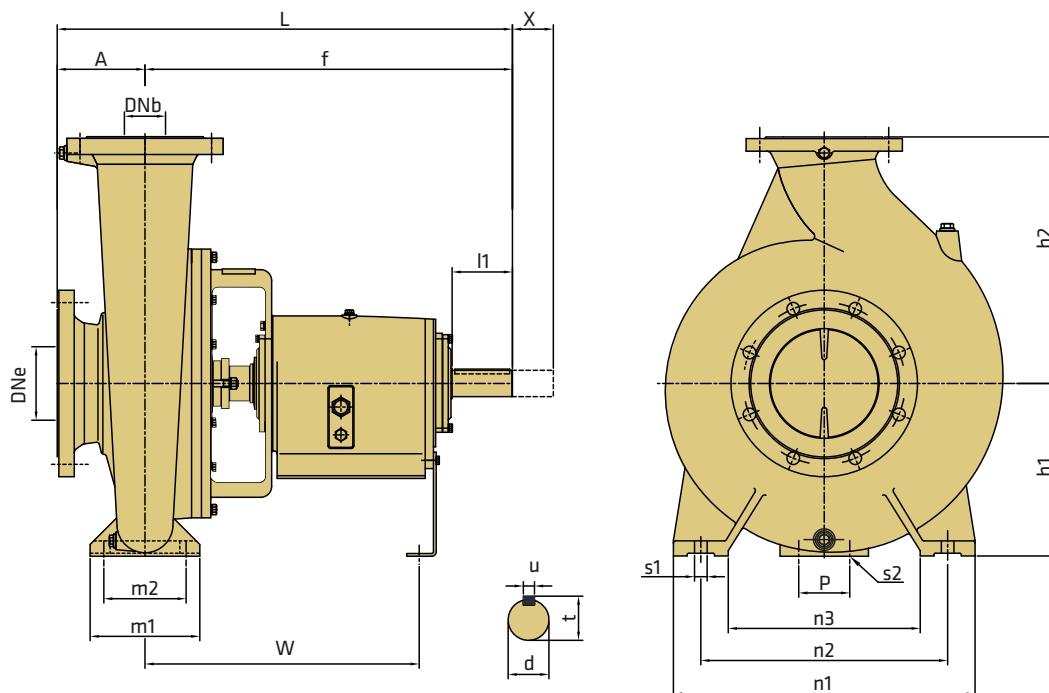

PUMP TYPE		Dimensions (mm)																				
ISO 2858	Additional	Overall Dimensions							Support and Foot Dimensions							Shaft End				Spacer		
		DNe	DNb	A	f	L	h1	h2	m1	m2	n1	n2	n3	s1	p	s2	w	d	l1	t	u	x
32-125		50	32	80	385	465	112	140	100	70	190	140	90	14	110	14	285	24	50	27	8	100
32-160		50	32	80	385	465	132	160	100	70	240	190	140	14	110	14	285	24	50	27	8	100
32-200		50	32	80	385	465	160	180	100	70	240	190	140	14	110	14	285	24	50	27	8	100
32-250		50	32	80	385	465	180	225	125	95	320	250	190	14	110	14	370	32	80	35	10	100
40-200		65	40	100	385	485	160	180	100	70	265	212	165	14	110	14	285	24	50	27	8	100
40-250		65	40	100	500	600	180	225	125	95	320	250	190	14	110	14	370	32	80	35	10	100
50-160		80	50	100	385	485	160	180	100	70	265	212	165	14	110	14	285	24	50	27	8	100
50-200		80	50	100	385	485	160	200	100	70	265	212	165	14	110	14	285	24	50	27	8	100
50-250		80	50	125	500	625	180	225	125	95	320	250	190	14	110	14	370	32	80	35	10	100
50-315		80	50	125	500	625	225	280	125	95	345	280	215	14	110	14	370	32	80	35	10	100
65-160		100	65	100	500	600	160	200	125	95	280	212	150	14	110	14	370	32	80	35	10	140
65-200		100	65	100	500	600	180	225	125	95	320	250	190	14	110	14	370	32	80	35	10	140
65-250		100	65	125	500	625	200	250	160	120	360	280	200	19	110	14	370	32	80	35	10	140
65-315		100	65	125	530	655	225	280	160	120	400	315	240	19	110	14	370	42	110	45	12	140
80-200		125	80	125	500	625	180	250	125	95	345	280	215	14	110	14	370	32	80	35	10	140
80-250		125	80	125	500	625	225	280	160	120	400	315	240	19	110	14	370	32	80	35	10	140
80-315		125	80	125	530	655	250	315	160	120	400	315	240	19	110	14	370	42	110	45	12	140
80-400		125	80	125	530	655	280	355	160	120	435	355	275	19	110	14	370	42	110	45	12	140
100-200		125	100	125	500	625	200	280	160	120	360	280	200	19	110	14	370	32	80	35	10	140
100-250		125	100	140	530	670	225	280	160	120	400	315	240	19	110	14	370	42	110	45	12	140
100-315		125	100	140	530	670	250	315	160	120	400	315	240	19	110	14	370	42	110	45	12	140
100-400		125	100	140	530	670	280	355	200	150	500	400	300	23	110	14	370	42	110	45	12	140
	125-200	150	125	140	500	640	250	315	160	120	400	315	240	19	110	14	370	32	80	35	10	140
125-250		150	125	140	530	670	250	355	160	120	400	315	240	19	110	14	370	42	110	45	12	140
125-315		150	125	140	530	670	280	355	200	150	500	400	300	23	110	14	370	42	110	45	12	140
125-400		150	125	140	530	670	315	400	200	150	500	400	300	23	110	14	370	42	110	45	12	140
	150-200	200	150	160	545	705	280	355	200	150	550	450	350	23	140	14	381	42	110	45	10	180
150-250		200	150	160	530	690	280	375	200	150	550	450	350	23	140	14	366	42	110	45	12	180
150-315		200	150	160	670	830	315	400	200	150	550	450	350	23	140	19	500	48	110	51,5	14	180
150-400		200	150	160	670	830	315	450	200	150	550	450	350	23	140	19	500	48	110	51,5	14	180
	150-500	200	150	200	730	930	400	525	250	200	720	600	435	27	140	19	495	55	110	59	16	140
	200-260	250	200	200	630	830	355	450	250	200	600	500	360	23	140	20	410	48	110	51,55	14	160
	200-315	250	200	200	684	884	355	450	250	200	600	500	360	23	140	20	520	48	110	45	14	160
	200-400	250	200	180	725	905	400	500	250	200	600	500	360	23	140	20	490	55	110	59	16	160
	200-500	250	200	210	925	1135	400	525	300	240	720	600	435	27	140	20	640	70	140	74,5	20	160
	250-315	300	250	230	730	960	400	525	300	240	720	600	435	27	140	20	515	55	110	59	16	200
	250-400	300	250	230	750	980	400	525	300	240	720	600	435	27	140	20	515	55	110	59	16	200
	250-500	300	250	225	940	1165	450	630	300	240	720	600	435	27	140	20	670	70	140	74,5	20	200

Note: All rights reserved due to dimension change.

Sectional Drawings

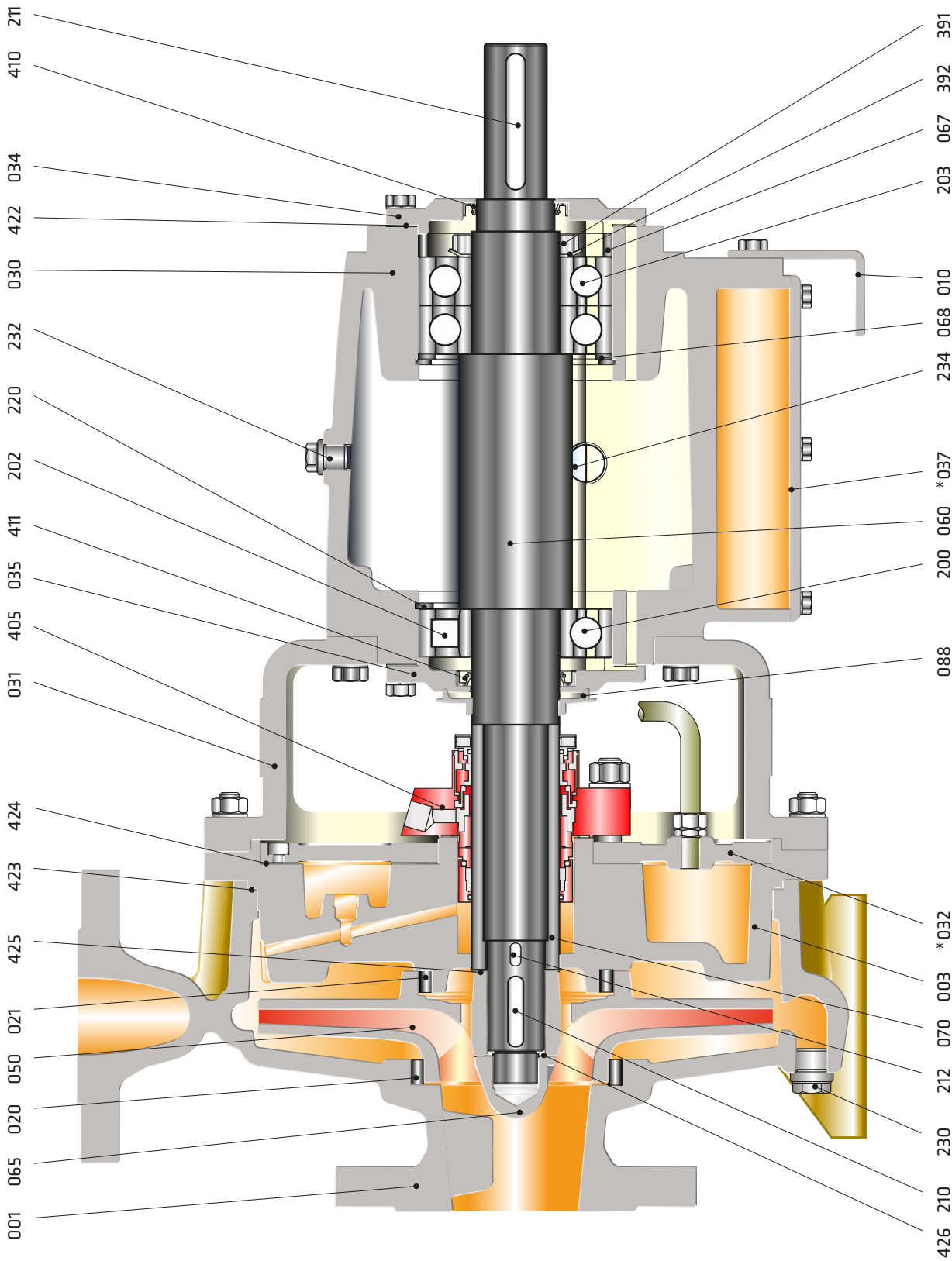

Sectional Drawings

Soft Packing Application

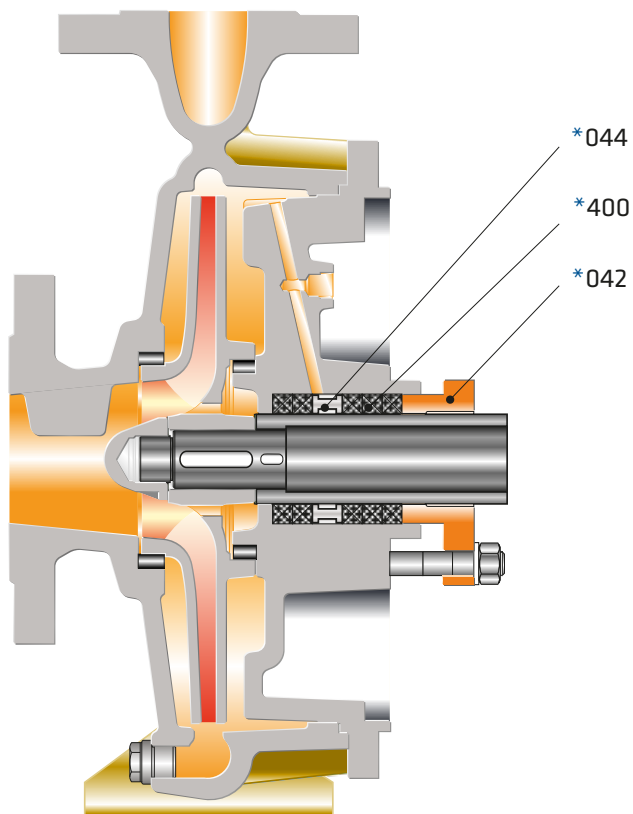

Semi-open Impeller Application

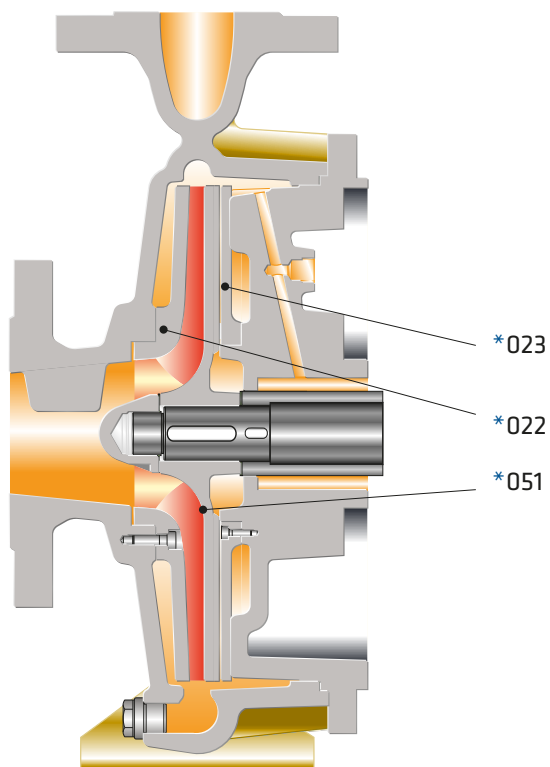

Part List

001	Volute Casing
003	Casing Cover
010	Support Foot
020	Wear Ring (casing)
021	Wear Ring (casing cover)
*022	Front Wear Plate
*023	Back Wear Plate
030	Bearing Bracket
031	Bearing Bracket Lantern
*032	Cooling-Heating Jacket Cover
034	Bearing Cover (outboard)
035	Bearing Cover (inboard)
*037	Bearing Cooling Cover
*042	Gland
*044	Lantern Ring
050	Impeller
*051	Semi-open impeller
060	Shaft
065	Impeller Nut
067	Bearing Spacer Sleeve
068	Bearing Spacer Sleeve
070	Shaft Protecting Sleeve
088	Thrower
200	Ball Bearing
202	Cylindrical Roller Bearing
203	Angular Contact Ball Bearing
210	Key (impeller)
211	Key (coupling)
212	Shaft Sleeve Key
220	Circlip
230	Drain Plug
232	Oil Filling Plug
234	Oil Sight Gauge
391	Shaft Nut
392	Lock Washer
*400	Soft Packing
405	Mechanical Seal
410	Lip Seal
411	Lip Seal
422	Gasket
423	Gasket
424	Gasket
425	Gasket
426	Gasket

* Optional

Technical Data

PART LIST	10	30	35	20	60	6L	70	7L	8M	7D	7S	8N	80	4C	4A	40	80	8T	60	7L	7E	7D	
	0.6025	0.7040	0.7043	1.0619	1.4308	1.4309	1.4408	1.4409	1.4500	1.4517	1.4469	1.4317	1.4008	2.1050.01	2.0975.01	2.1096.01	1.4021	1.4021+QT	1.4301	1.4404	1.4460	1.4462	
Volute Casing	●	○	○	○	○	○	○	○	○	○	○	○	○	○	○	○							
Casing Cover	●	○	○	○	○	○	○	○	○	○	○	○	○	○	○	○							
Impeller	●	○	○	○	○	○	○	○	○	○	○	○	○	○	○	○						○	
Shaft																	●	○	○	○			○
Bearing Bracket	●	○	○	○	○	○	○	○															
Wear Ring	●	○	○	○	○	○	○	○	○	○	○	○	○	○	○	○							
Shaft Protecting Sleeve																	●	○	○	○			○
Mechanical Seal (*)	EN 12756																						

(*) Optional :Depending on customer requirement or request different types and brands of mechanical seals are applicable.

● Standard manufacturing
○ Optional

Material Equivalents

Description	DIN / EN		AISI / SAE / ASTM
Cast Iron	0.6025	EN-GJL-250 (GG25)	A48 Class 40B
Nodular Cast Iron	0.7040	EN-GJS-400-15 (GGG40)	A536 60-40-18
Nodular Cast Iron	0.7043	EN-GJS-400-18-LT (GGG40.3)	A536 60-40-18
Cast Steel	1.0619	GP240GHGS-C25	A216 WCB
Chrome Nickel Cast Steel	1.4308	GX5CrNi19-10	A351 CF8
Chrome Nickel Cast Steel (low carbon)	1.4309	GX2CrNi19-11	A351 CF3
Chrome Nickel Molybdenum Cast Steel	1.4408	GX5CrNiMo19-11-2	A351 CF8M
Chrome Nickel Molybdenum Cast Steel (low carbon)	1.4409	GX2CrNiMo19-11-2	A351 CF3M
Austenitic Cast Steel	1.4500	GX7NiCrMoCuNb25-20	A351 CN7M
Austenitic - Ferritic Cast Steel (duplex)	1.4517	GX2CrNiMoCuN25-6-3-3	A890 CD4MCuN
Austenitic - Ferritic Cast Steel (super duplex)	1.4469	GX2CrNiMoN26-7-4	A890 CE3MN
Martenzitic Stainless Cast Steel	1.4317	GX4CrNi13-4	A352 CA6NM
Martenzitic Stainless Cast Steel	1.4008	GX7CrNiMo12-1	A217 CA15
Cast Bronze (tin alloy)	2.1050.01	G-CuSn10	B427 C90700
Cast Bronze (nickel alloy)	2.0975.01	G-CuAl10Ni	B148 C95500
Cast Bronze (lead)	2.1096.01	G-CuSn5ZnPb	B584 C83600
Chrome Steel	1.4021	X20Cr13	A276 Type 420
Chrome Steel(heat treated)	1.4021	X20Cr13	A276 Type 420+QT
Chrome Nickel Steel	1.4301	X5CrNi18-10	A276 Type 304
Chrome Nickel Steel (low carbon)	1.4404	X2CrNiMo17-12-2	A276 Type 316L
Duplex (austenitic-ferritic) Steel	1.4460	X3CrNiMoN27-5-2	AISI 329
Duplex (austenitic-ferritic) Steel	1.4462	X2CrNiMoN22-5-3	UNS S32205

Flange Dimensions

EN 1092 - 2	DNe/DNb	Suction & Discharge (PN 16)			
		Df	k	s	n
	32	140	100	19	4
	40	150	110	19	4
	50	165	125	19	4
	65	185	145	19	4
	80	200	160	19	8
	100	220	180	19	8
	125	250	210	19	8
	150	285	240	23	8
	200	340	295	23	12
	250	405	355	28	12
	300	460	410	28	12

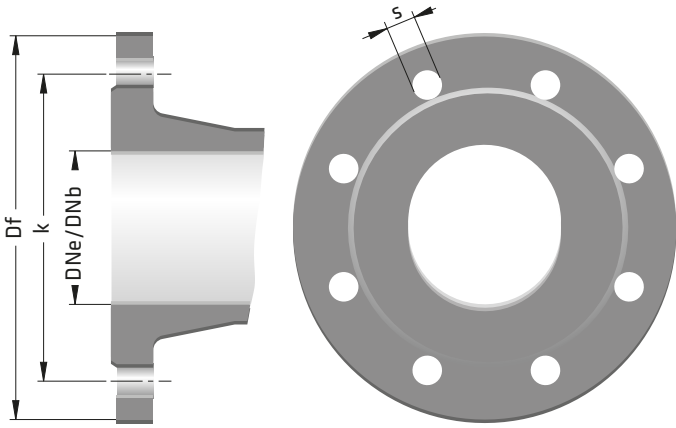

“ n “ number of holes