

N-FM

EN 733 NORM PUMPS



Handled Liquids

Clean or slightly contaminated low viscosity liquids without solid & fibrous particles.

Technical Data

Discharge Flange _____ DN 32.....DN 150 mm

Capacity _____ up to 600 m³/h (*)

Head _____ up to 100 m (*)

Operating Temperature _____ -10 °C' to +140 °C (**)

Casing Pressure (Pmax) _____ 10 bar (16 bar) (**)

(Pmax: Suction Pressure + Shut off Head)

(*) Contact company for higher capacity and head values.

(**) The Material of pump differs according to the type of pumped liquid, operating temperature and pressure. Contact for detailed information.

Design Features

- Horizontal , radially split volute casing type , single stage, end suction centrifugal pump with closed impeller.
- Dimensionally complies with EN 733.
- In addition to 24 basic sizes conforming with EN 733, there are 8 additional sizes. Dimensions of additional sizes may differ from other suppliers.
- N-FM 40-315, 50-315, 65-315, 80-315, 100-315, 125-250 pumps are given with 2900 rpm only for fire fighting application.

Pump Designation

Pump Type _____

Discharge Nozzle (DN-mm) _____

Nominal Impeller Diameter (mm) _____

Special Application _____

- Suction and discharge flanges conform to EN 1092-2/ PN 16. For steel or stainless steel casing is EN 1092-1/ PN 16. In case of request, ANSI/ASME flanges can be supplied.

- Due to the back-pull-out design, the complete bearing assembly including impeller and casing cover can be dismantled without removing the volute casing from the pipe system. With spacer coupling application, also possible to take out the rotor group without dismantling the electric motor.

- All impellers are balanced dynamically or statically according to ISO 1940 grade 6.3.

- Axial thrust is balanced by impeller balancing holes system.

- Direction of rotation is clockwise viewed from drive end.

- In case of request, wear ring and/or shaft sleeve can be supplied.

- Bearings of N-FM type pumps are normally "life time grease lubricated" ball bearings. If there is a demand, oil lubrication or re-greasable bearing can be supplied.

- For N-FM drawings, please look at below adress www.dynapumps.com.au

Shaft Sealing

- In standard production, soft packed stuffing boxes are used.

- Depending on customer request, mechanical seals are available. In this case, pump shaft is always stainless steel.

N-FM 100 - 250 - XXX

Field Charts

N-FM - 1450 rpm

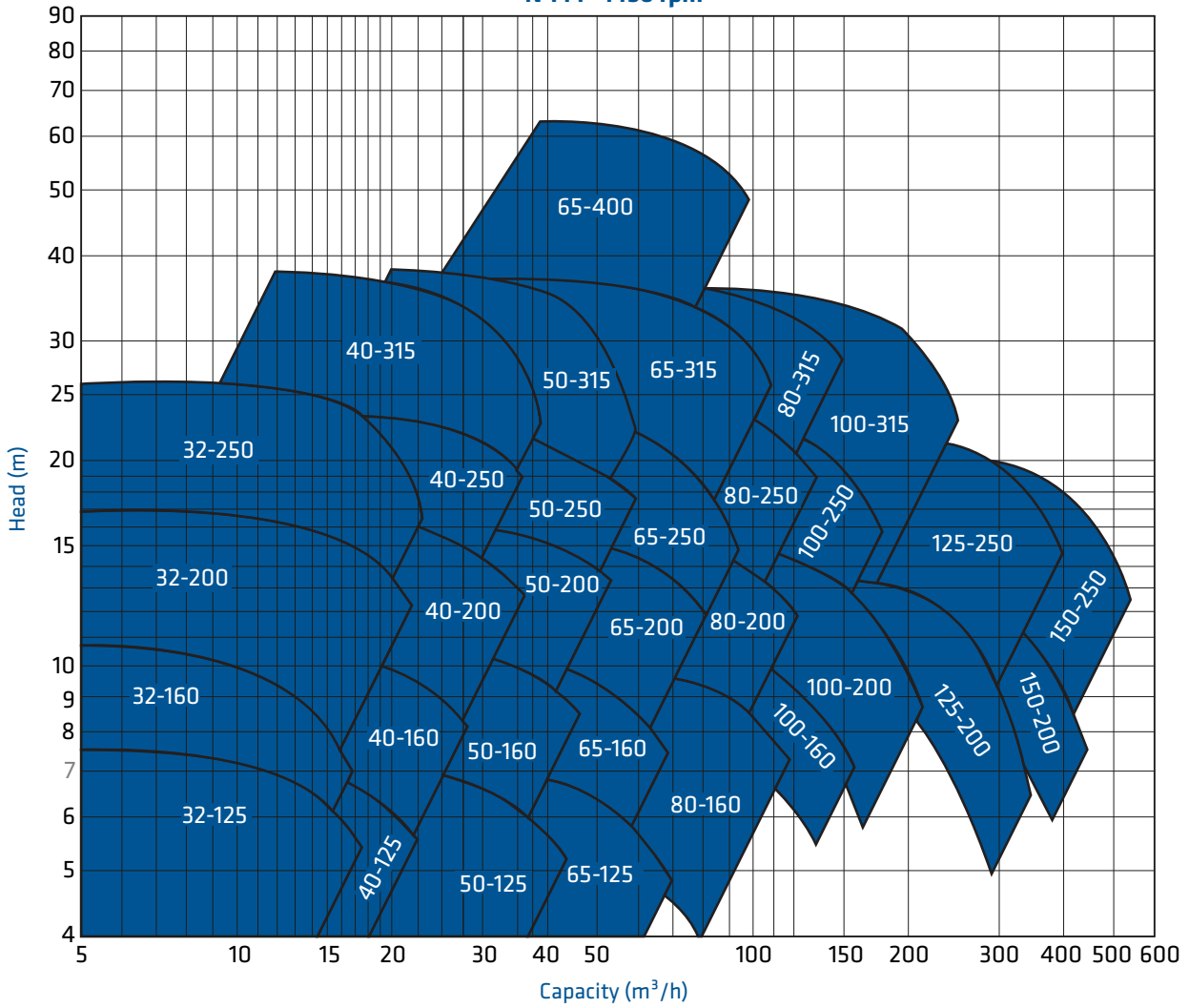

N-FM - 2900 rpm

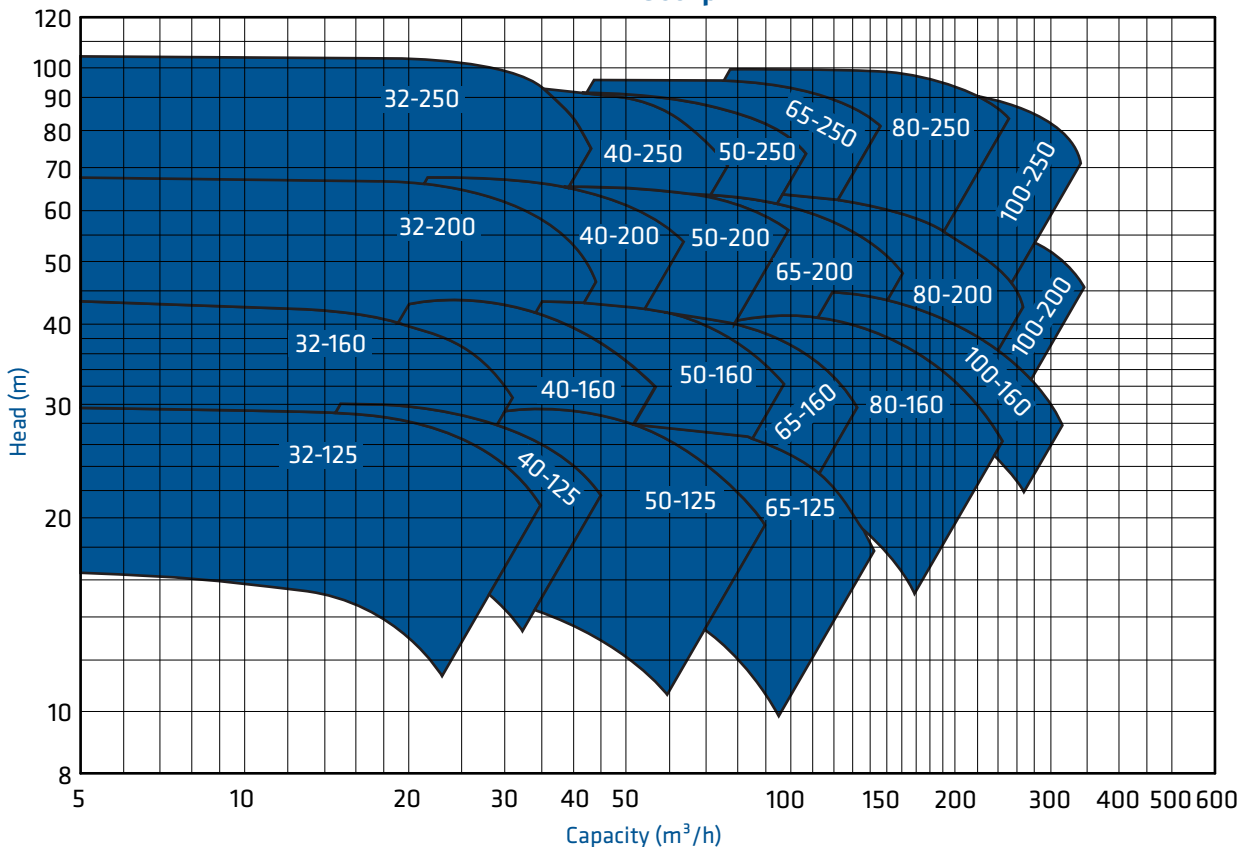

Dimensions

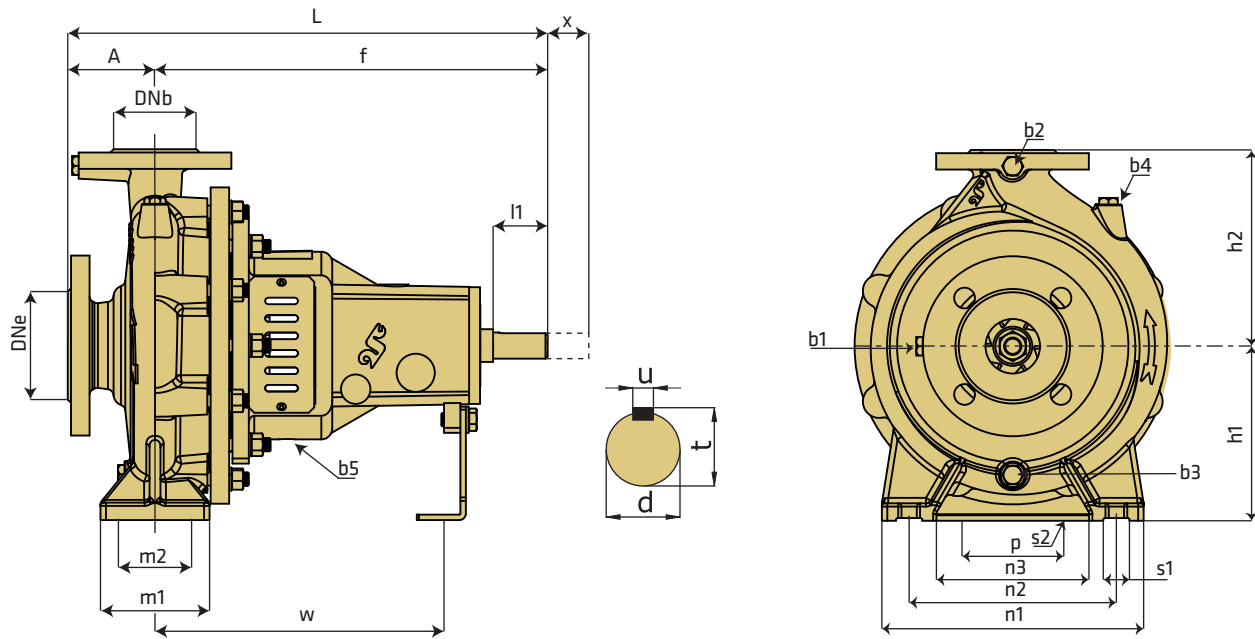

Pump Type		Form	Overall Dimensions										Support & Foot Dimensions					Shaft End					Weight	Space					
EN 733	Other		DN _e	DN _b	A	f	L	h ₁	h ₂	m ₁	m ₂	n ₁	n ₂	n ₃	s ₁	p	s ₂	w	d	l ₁	t	u	b ₁	b ₂	b ₃	b ₄	b ₅	(kg)	x ^{**}
32-125		F1	50	32	80	360	440	112	140	100	70	190	140	90	14	110	14	260	24	50	27	8	1 1/4"	1 1/4"	1 1/4"	1 1/4"	3/8"	32	100
32-160		F1	50	32	80	360	440	132	160	100	70	240	190	140	14	110	14	260	24	50	27	8	1 1/4"	1 1/4"	1 1/4"	1 1/4"	3/8"	39	100
32-200		F2	50	32	80	360	440	160	180	100	70	240	190	140	14	110	14	260	24	50	27	8	1 1/4"	1 1/4"	1 1/4"	1 1/4"	3/8"	41	100
	32-250	F2	50	32	100	360	460	180	225	125	95	320	250	190	14	110	14	260	24	50	27	8	1 1/4"	1 1/4"	1 1/4"	1 1/4"	3/8"	53	100
40-125		F1	65	40	80	360	440	112	140	100	70	210	160	110	14	110	14	260	24	50	27	8	1 1/4"	1 1/4"	1 1/4"	1 1/4"	3/8"	33	100
40-160		F1	65	40	80	360	440	132	160	100	70	240	190	140	14	110	14	260	24	50	27	8	1 1/4"	1 1/4"	1 1/4"	1 1/4"	3/8"	40	100
40-200		F2	65	40	100	360	460	160	180	100	70	265	212	165	14	110	14	260	24	50	27	8	1 1/4"	1 1/4"	1 1/4"	1 1/4"	3/8"	45	100
40-250		F2	65	40	100	360	460	180	225	125	95	320	250	190	14	110	14	260	24	50	27	8	1 1/4"	1 1/4"	1 1/4"	1 1/4"	3/8"	57	100
	40-315	F2	65	40	100	360	460	200	250	125	95	345	280	190	14	110	14	260	24	50	27	8	1 1/4"	1 1/4"	1 1/4"	1 1/4"	3/8"	67	100
50-125		F1	65	50	100	360	460	132	160	100	70	240	190	140	14	110	14	260	24	50	27	8	1 1/4"	1 1/4"	1 1/4"	1 1/4"	3/8"	34	100
50-160		F1	65	50	100	360	460	160	180	100	70	265	212	165	14	110	14	260	24	50	27	8	1 1/4"	1 1/4"	1 1/4"	1 1/4"	3/8"	42	100
50-200		F2	65	50	100	360	460	160	200	100	70	265	212	165	14	110	14	260	24	50	27	8	1 1/4"	1 1/4"	1 1/4"	1 1/4"	3/8"	48	100
50-250		F2	65	50	100	360	460	180	225	125	95	320	250	190	14	110	14	260	24	50	27	8	1 1/4"	1 1/4"	1 1/4"	1 1/4"	3/8"	57	100
	50-315	F2	65	50	125	470	595	225	280	125	95	345	280	190	19	110	14	340	32	80	35	10	1 1/4"	1 1/4"	1 1/4"	1 1/4"	3/8"	90	100
65-125		F1	80	65	100	360	460	160	180	125	95	280	212	150	14	110	14	260	24	50	27	8	1 1/4"	1 1/4"	3/8"	3/8"	3/8"	40	100
65-160		F1	80	65	100	360	460	160	200	125	95	280	212	150	14	110	14	260	24	50	27	8	1 1/4"	1 1/4"	3/8"	3/8"	3/8"	46	100
65-200		F2	80	65	100	360	460	180	225	125	95	320	250	190	14	110	14	260	24	50	27	8	1 1/4"	1 1/4"	3/8"	3/8"	3/8"	51	140
65-250		F2	80	65	100	470	570	200	250	160	120	360	280	200	19	110	14	340	32	80	35	10	1 1/4"	1 1/4"	3/8"	3/8"	3/8"	90	140
65-315		F2	80	65	125	470	595	225	280	160	120	400	315	240	19	110	14	340	32	80	35	10	1 1/4"	1 1/4"	3/8"	3/8"	3/8"	105	140
	65-400	F2	100	65	125	470	595	260	355	160	120	435	355	275	19	110	14	340	32	80	35	10	1 1/4"	1 1/4"	3/8"	3/8"	3/8"	130	140
80-160		F1	100	80	125	360	485	180	225	125	95	320	250	190	14	110	14	260	24	50	27	8	1 1/4"	1 1/4"	3/8"	3/8"	3/8"	49	140
80-200		F1	100	80	125	470	595	180	250	125	95	345	280	215	14	110	14	340	32	80	35	10	1 1/4"	1 1/4"	3/8"	3/8"	3/8"	63	140
80-250		F2	100	80	125	470	595	200	280	160	120	400	315	240	19	110	14	340	32	80	35	10	1 1/4"	1 1/4"	3/8"	3/8"	3/8"	95	140
80-315		F2	100	80	125	470	595	250	315	160	120	400	315	240	19	110	14	340	32	80	35	10	1 1/4"	1 1/4"	3/8"	3/8"	3/8"	125	140
	100-160	F1	125	100	125	470	595	200	280	160	120	360	280	200	19	110	14	340	32	80	35	10	1 1/4"	1 1/4"	3/8"	3/8"	3/8"	80	140
100-200		F1	125	100	125	470	595	200	280	160	120	360	280	200	19	110	14	340	32	80	35	10	1 1/4"	1 1/4"	3/8"	3/8"	3/8"	87	140
100-250		F2	125	100	140	470	610	225	280	160	120	400	315	240	19	110	14	340	32	80	35	10	1 1/4"	1 1/4"	3/8"	3/8"	3/8"	100	140
100-315		F2	125	100	140	470	610	250	315	160	120	400	315	240	19	110	14	340	32	80	35	10	1 1/4"	1 1/4"	3/8"	3/8"	3/8"	130	140
	125-200	F1	150	125	140	470	610	250	315	160	120	400	315	240	19	110	14	340	32	80	35	10	1 1/4"	1 1/4"	1/2"	1/2"	3/8"	97	140
125-250		F2	150	125	140	470	610	250	355	160	120	400	315	240	19	110	14	340	32	80	35	10	1 1/4"	1 1/4"	1/2"	1/2"	3/8"	110	140
	150-200	F1	200	150	160	470	630	280	355	200	150	500	400	300	23	110	14	340	32	80	35	10	1 1/4"	1 1/4"	1/2"	1/2"	3/8"	150	140
	150-250	F2	200	150	160	470	630	280	375	200	150	500	400	300	23	110	14	340	32	80	35	10	1 1/4"	1 1/4"	1/2"	1/2"	3/8"	160	140

(**) Gap necessary for the withdrawal of the pump rotor from the driven end without the need for dismantling the motor and pipework (spacer coupling application)

Assembly Drawings

Form: F1 (Soft Packing Seal Pump)

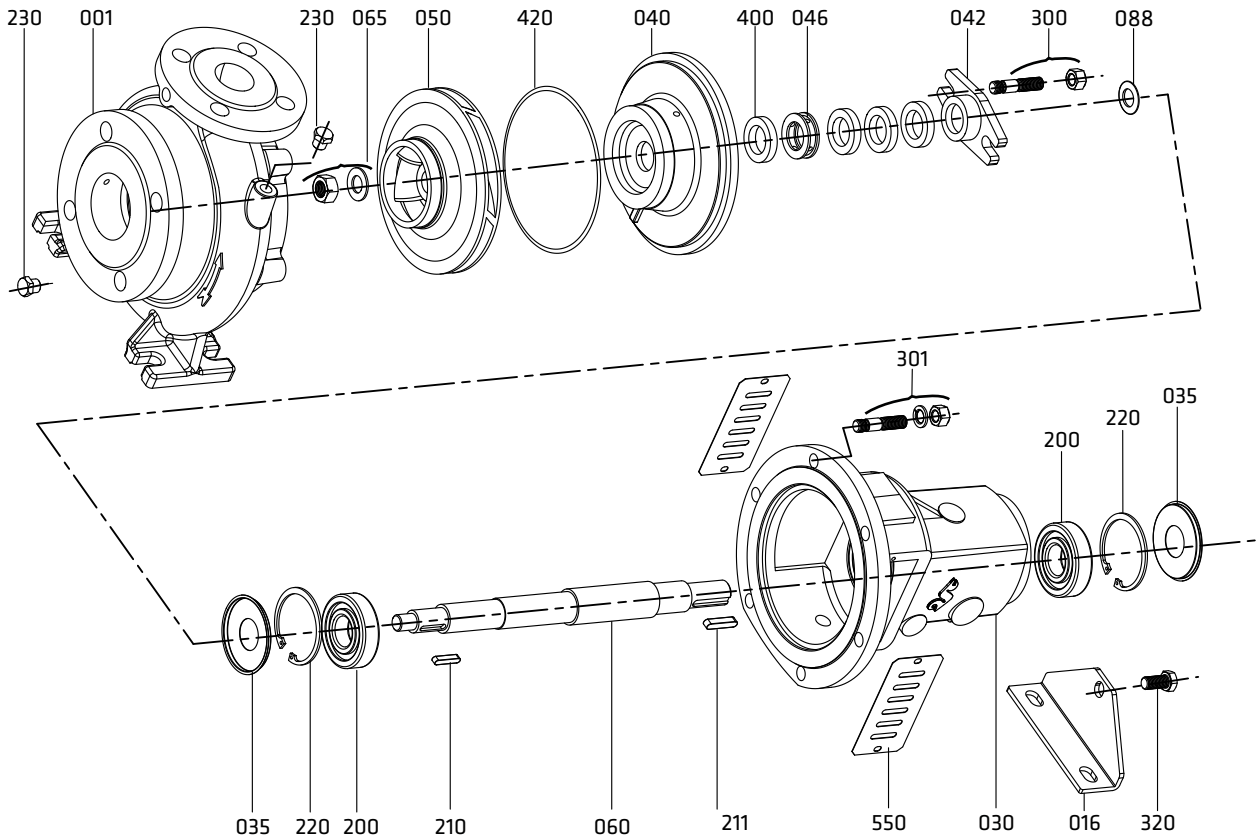

Form: F2 (Soft Packing Seal Pump)

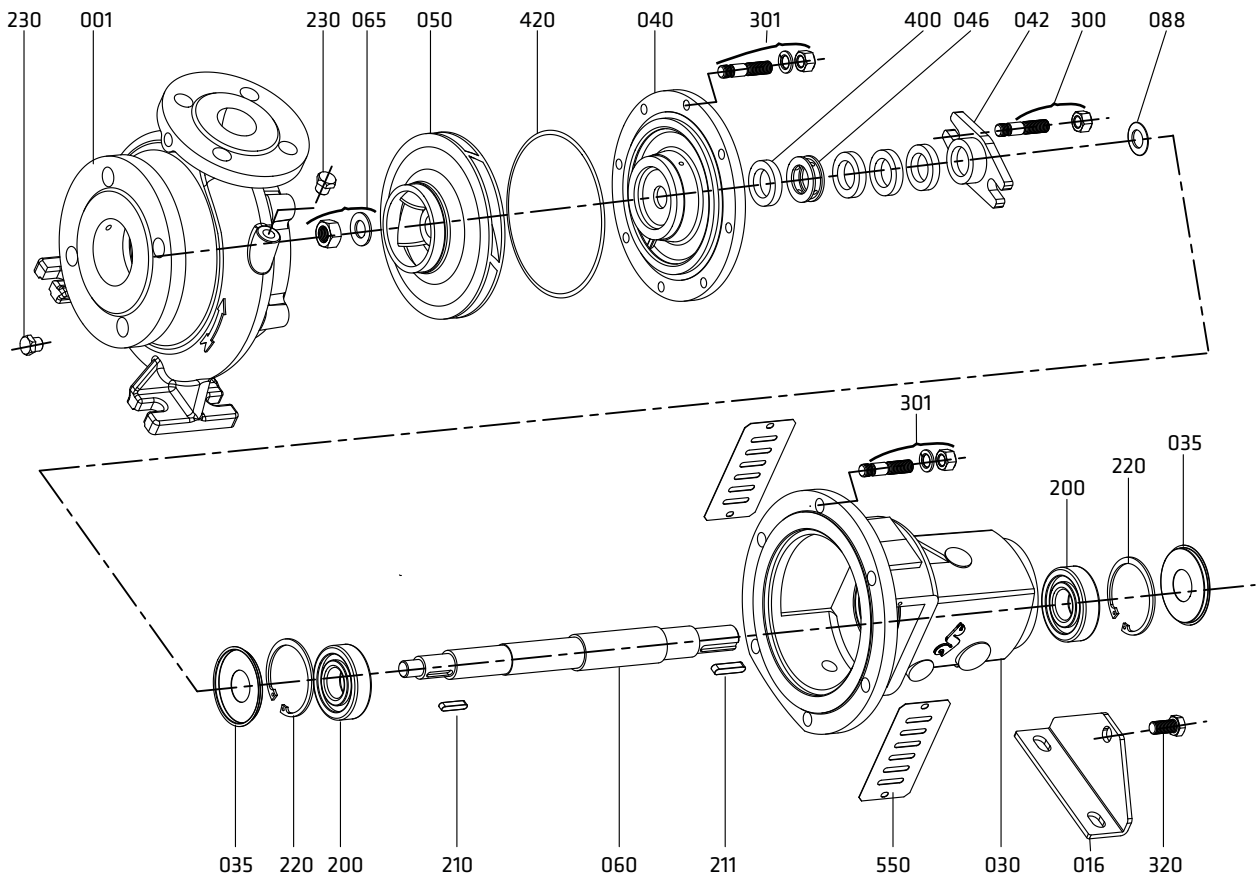

Assembly Drawings

Form: F1 (Mechanical Seal Pump)

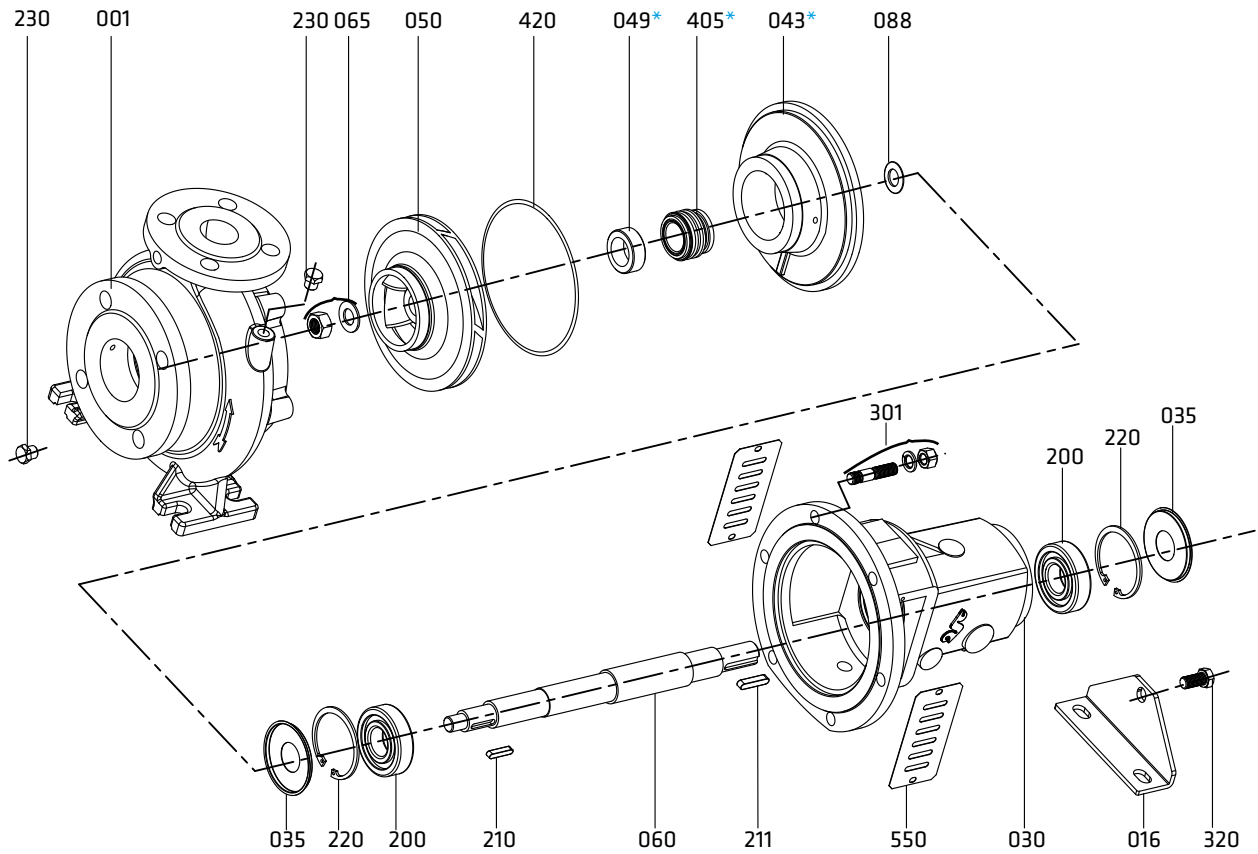

Form: F2 (Mechanical Seal Pump)

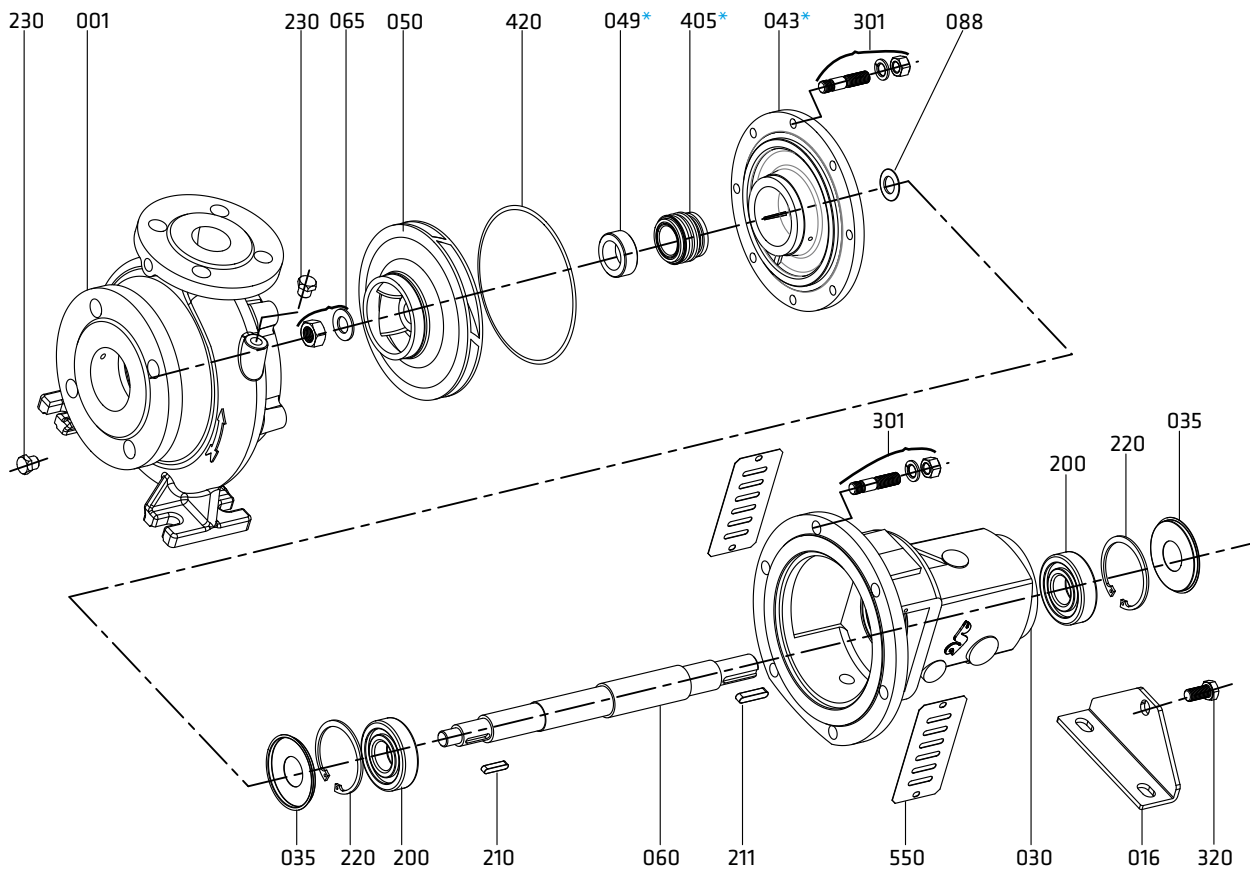

Assembly Drawings

Oil Lubrication Bearing Housing

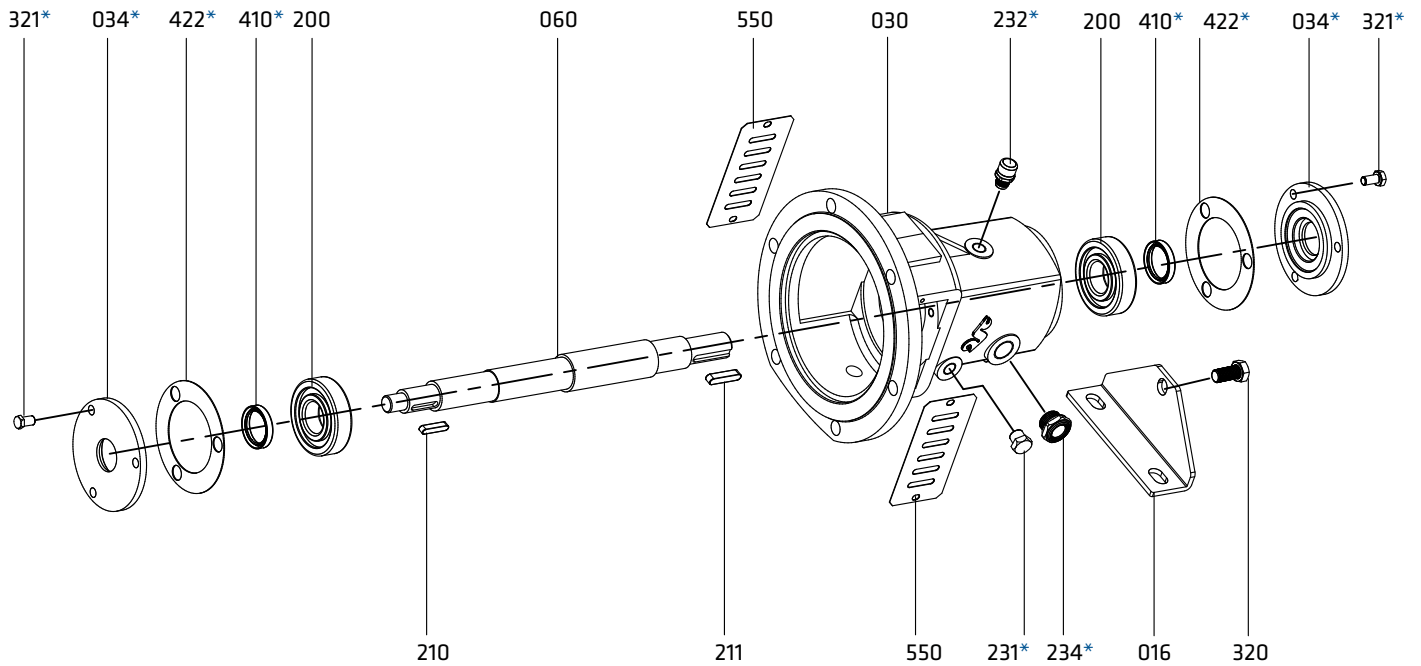

Re-greasable Bearing Housing

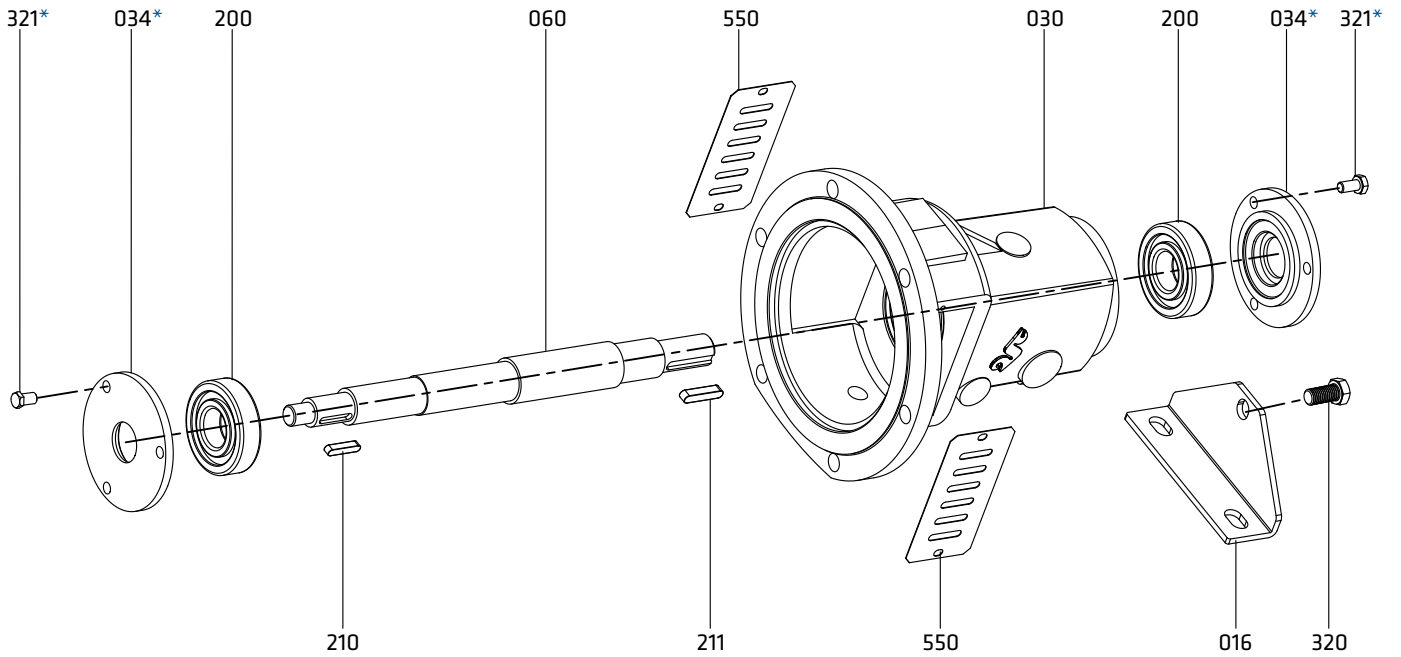

Assembly Drawings

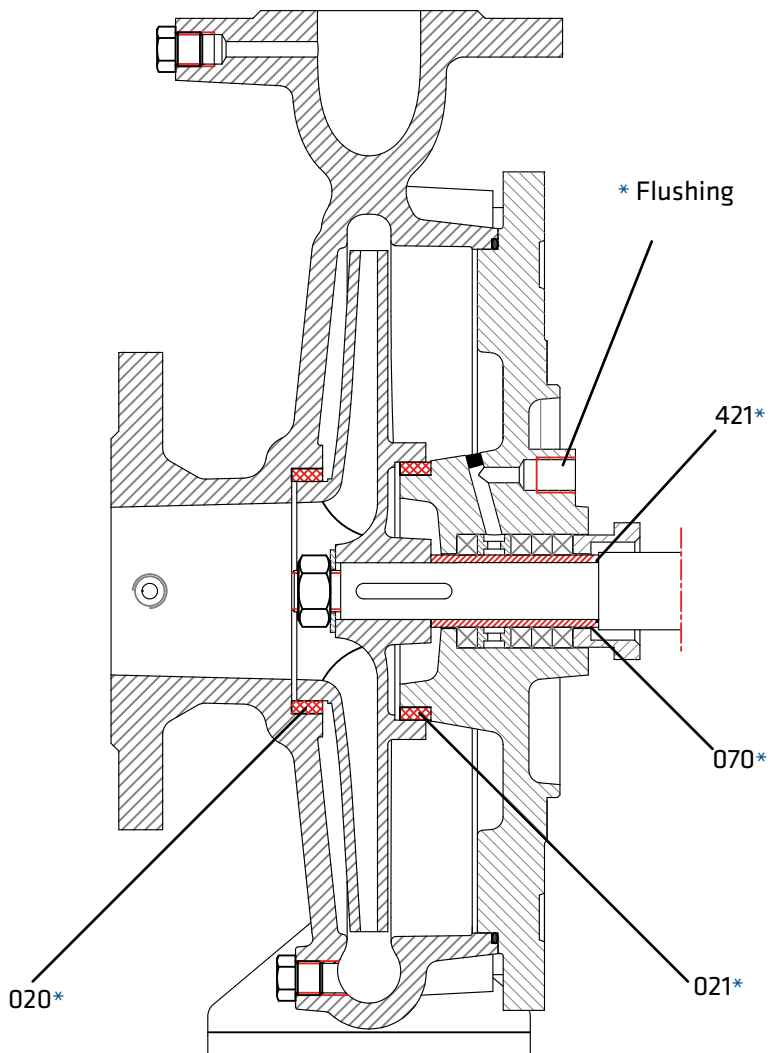

Part List

001	Volute Casing
016	Support Foot
020*	Wear Ring (Casing)
021*	Wear Ring (Seal Cover)
030	Bearing Housing
034*	Bearing Cover (GG)
035	Bearing Cover (St)
040	Soft Packing Seal Cover
042	Gland
043*	Mechanical Seal Cover
046	Lantern Ring
049*	Mechanical Seal Spacer Sleeve
050	Impeller
060	Shaft
065	Impeller Nut and Washer
070*	Shaft Sleeve
088	Thrower
200	Ball Bearing
210	Impeller Key
211	Coupling Key
220	Circlip
230	Screw
231*	Screw
232*	Oil Filling Plug and Breather
234*	Oil Level Indicator
300	Gland Stud and Nut
301	Stud, Washer and Nut
320	Screw
321*	Screw
400	Soft Packing
405*	Mechanical Seal
410*	Lip Seal
420	O-ring
421*	O-ring
422*	Gasket
550	Guard

(*) Optional

Technical Data

Part List	10	30	35	20	60	6L	70	7L	8M	7D	7S	8N	80	4C	4A	40	20	80	8T	60	7L	7E	7D	
	0.6025	0.7040	0.7043	1.0619	1.4308	1.4309	1.4408	1.4409	1.4500	1.4517	1.4469	1.4317	1.4008	2.1050.01	2.0975.01	2.1096.01	1.0503	1.4021	1.4021+QT	1.4301	1.4404	1.4460	1.4462	
Volute Casing	●	○	○	○	○	○	○	○	○	○	○	○	○	○	○	○								
Seal Cover (Mech. or Soft)	●	○	○	○	○	○	○	○	○	○	○	○	○	○	○	○								
Impeller	●	○	○	○	○	○	○	○	○	○	○	○	○	○	○	○							○	
Shaft																	●	○	○	○	○			○
Bearing House	●	○	○	○	○	○	○	○																
Wear Ring	○	○	○	○	○	○	○	○	○	○	○	○	○	○	○	○								
Shaft Sleeve																	○	○	○	○	○			○
Mechanical Seal (*)	EN 12756																							

(*) Optional :Depending on customer requirement or request different types and brands of mechanical seals are applicable.
 NOTE: Depends on the request, different than above casting and shaft material can be supplied.

● Standard manufacturing
 ○ Optional

Material Equivalents

Description	DIN / EN	AISI / SAE / ASTM	
Cast Iron	0.6025	EN-GJL-250 (GG25)	A48 Class 40B
Nodular Cast Iron	0.7040	EN-GJS-400-15 (GGG40)	A536 60-40-18
Nodular Cast Iron	0.7043	EN-GJS-400-18-LT (GGG40.3)	A536 60-40-18
Cast Steel	1.0619	GP240GHGS-C25	A216 WCB
Chrome Nickel Cast Steel	1.4308	GX5CrNi19-10	A351 CF8
Chrome Nickel Cast Steel (low carbon)	1.4309	GX2CrNi19-11	A351 CF3
Chrome Nickel Molybdenum Cast Steel	1.4408	GX5CrNiMo19-11-2	A351 CF8M
Chrome Nickel Molybdenum Cast Steel (low carbon)	1.4409	GX2CrNiMo19-11-2	A351 CF3M
Austenitic Cast Steel	1.4500	GX7NiCrMoCuNb25-20	A351 CN7M
Austenitic - Ferritic Cast Steel (duplex)	1.4517	GX2CrNiMoCuN25-6-3-3	A890 CD4MCuN
Austenitic - Ferritic Cast Steel (super duplex)	1.4469	GX2CrNiMoN26-7-4	A890 CE3MN
Martenzitic Stainless Cast Steel	1.4317	GX4CrNi13-4	A352 CA6NM
Martenzitic Stainless Cast Steel	1.4008	GX7CrNiMo12-1	A217 CA15
Cast Bronze (tin alloy)	2.1050.01	G-CuSn10	B427 C90700
Cast Bronze (nickel alloy)	2.0975.01	G-CuAl10Ni	B148 C95500
Cast Bronze (Leaded)	2.1096.01	G-CuSn5ZnPb	B584 C83600
Carbon Steel	1.0503	C45	AISI 1045
Chrome Steel	1.4021	X20Cr13	A276 Type 420
Chrome Steel (Heat treated)	1.4021	X20Cr13	A276 Type 420+QT
Chrome Nickel Steel	1.4301	X5CrNi18-10	A276 Type 304
Chrome Nickel Steel (low carbon)	1.4404	X2CrNiMo17-12-2	A276 Type 316L
Duplex (austenitic-ferritic) Steel	1.4460	X3CrNiMoN27-5-2	AISI 329
Duplex (austenitic-ferritic) Steel	1.4462	X2CrNiMoN22-5-3	UNS S32205

Flange Dimensions

DNe/DNb	Suction & Discharge (PN 16)			
	Df	k	s	n
32	140	100	19	4
40	150	110	19	4
50	165	125	19	4
65	185	145	19	4
80	200	160	19	8
100	220	180	19	8
125	250	210	19	8
150	285	240	23	8
200	340	295	23	12

EN 1092 - 2

“ n “ number of holes