

IL-FM

IN-LINE PUMPS



Handled Liquids

Clean or slightly contaminated low viscosity liquids without solid & fibrous particles.

Technical Data

Discharge Flange _____ DN 40.....DN 150 mm

Capacity _____ up to 200 m³/h(*)

Head _____ up to 100 m(*)

Operating Temperature _____ -10 °C' to +140 °C(**)

Casing Pressure (Pmax) _____ 10 bar (16 bar)(**)
(Pmax: Suction Pressure + Shut off Head)

(*) Contact company for higher capacity and head values.
(**) The Material of pump differs according to the type of pumped liquid, operating temperature and pressure. Contact for detailed information.

Design Features

- In-line, rigidly-coupled, volute casing, single stage centrifugal pump with closed impeller.
- All impellers are balanced dynamically or statically according to ISO 1940 grade 6.3.
- Suction and discharge flanges conform to EN 1092-2 / PN 16. The flanges are according to EN 1092-1 / PN 16 for steel or stainless steel casing. In case of request, ANSI/ASME flanges can be supplied.
- Pumps are rigidly coupled with electric motors of IEC frame sizes with high efficiency class.

Pump Designation

Pump Type _____

Suction and Discharge Nozzle (DN-mm) _____

Nominal Impeller Diameter (mm) _____

Special Application _____

- All impellers are balanced dynamically or statically according to ISO 1940 grade 6.3.
- Axial thrust is balanced by impeller balancing holes system.
- Direction of rotation is clockwise viewed from drive end.
- In case of request, wear ring and/or shaft sleeve can be supplied.
- The pump and motor have separate shafts connected by a rigid coupling or through slide fit shaft. Axial and radial forces are absorbed by electric motor bearings.
- For IL-FM drawings, please look at below address www.dynapumps.com.au

Shaft Sealing

- Depending on customer request or liquid type, mechanical seals are available.

IL-FM 100 - 250 - XXX



Field Charts

IL-FM - 1450 rpm

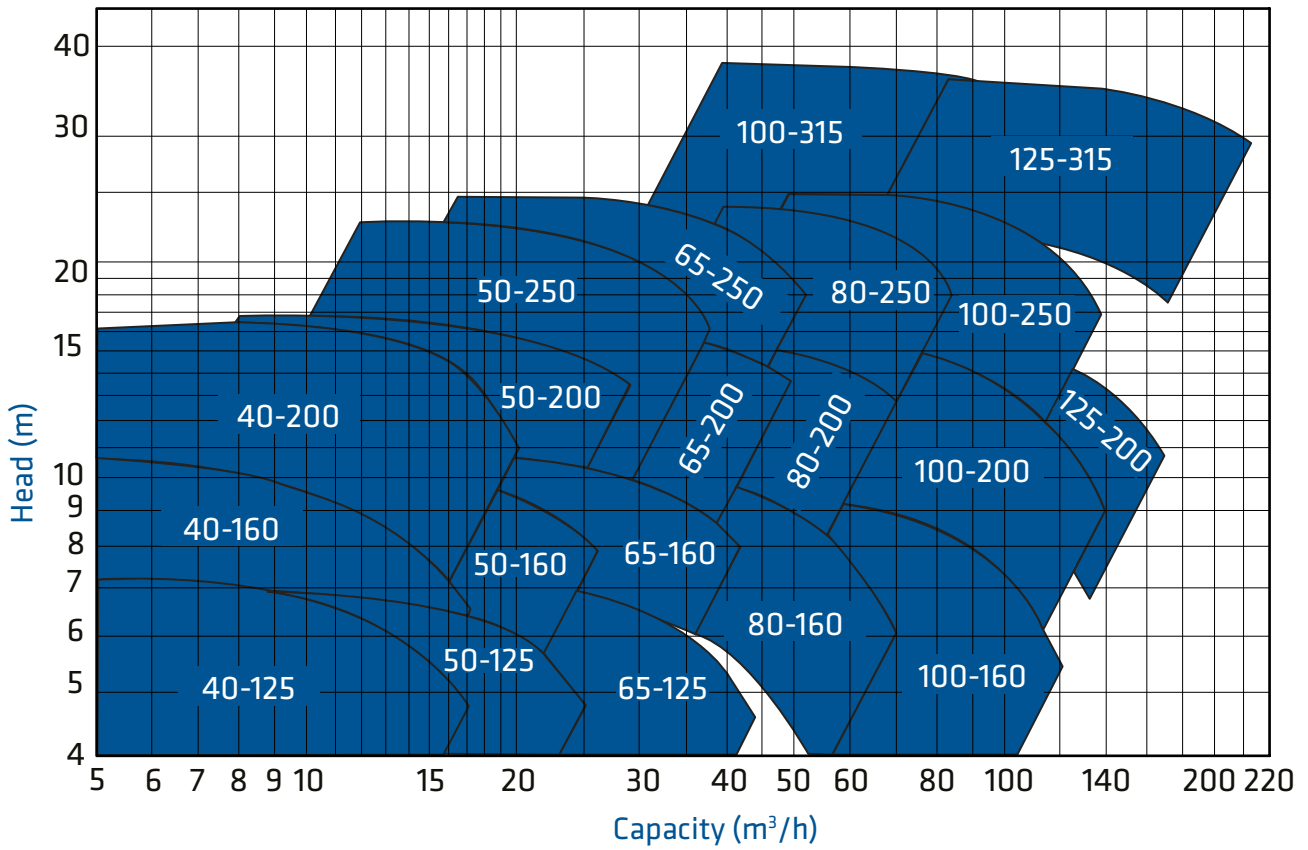

IL-FM - 2900 rpm

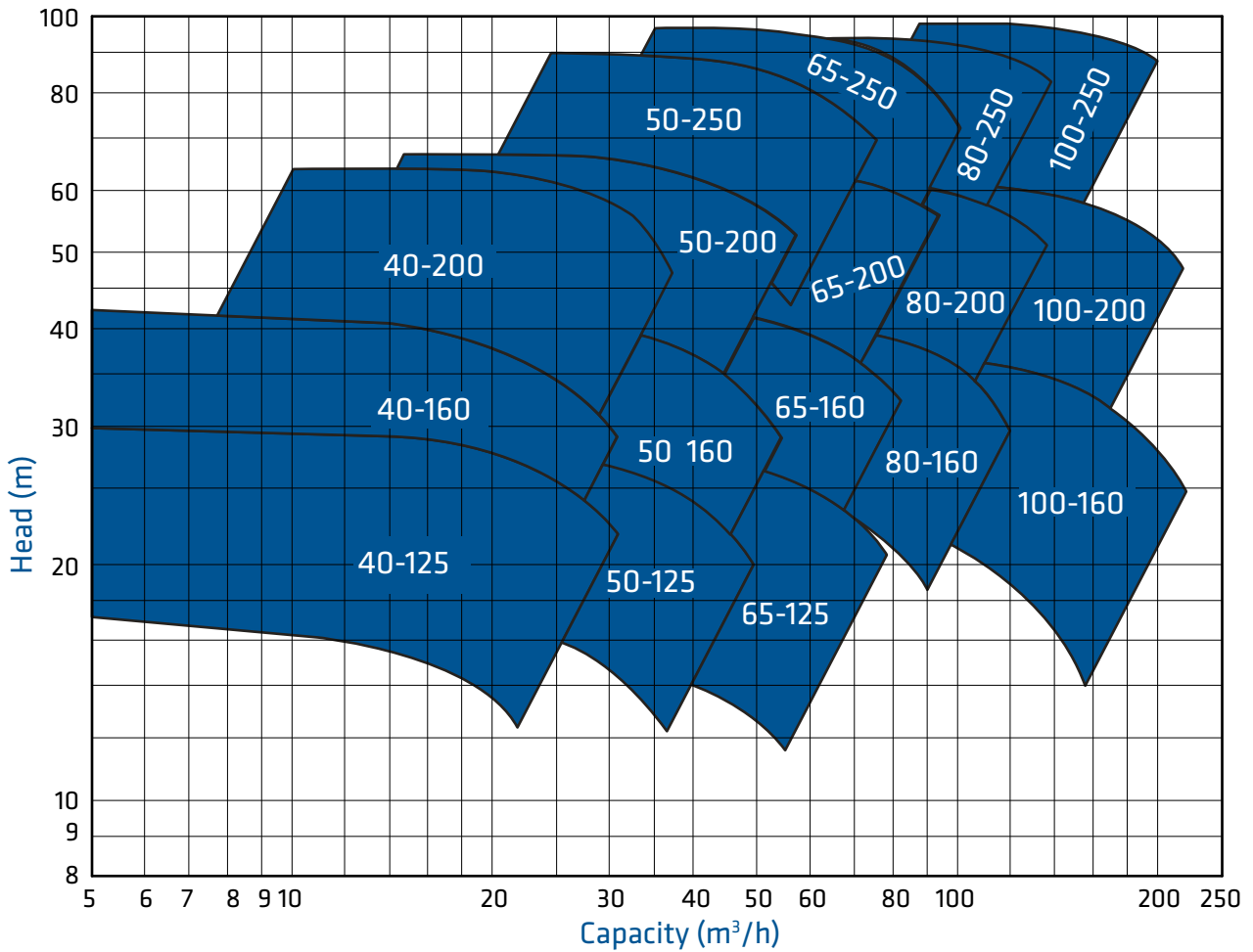

Assembly Drawings

Form: F1 (Slide - fit shaft application)

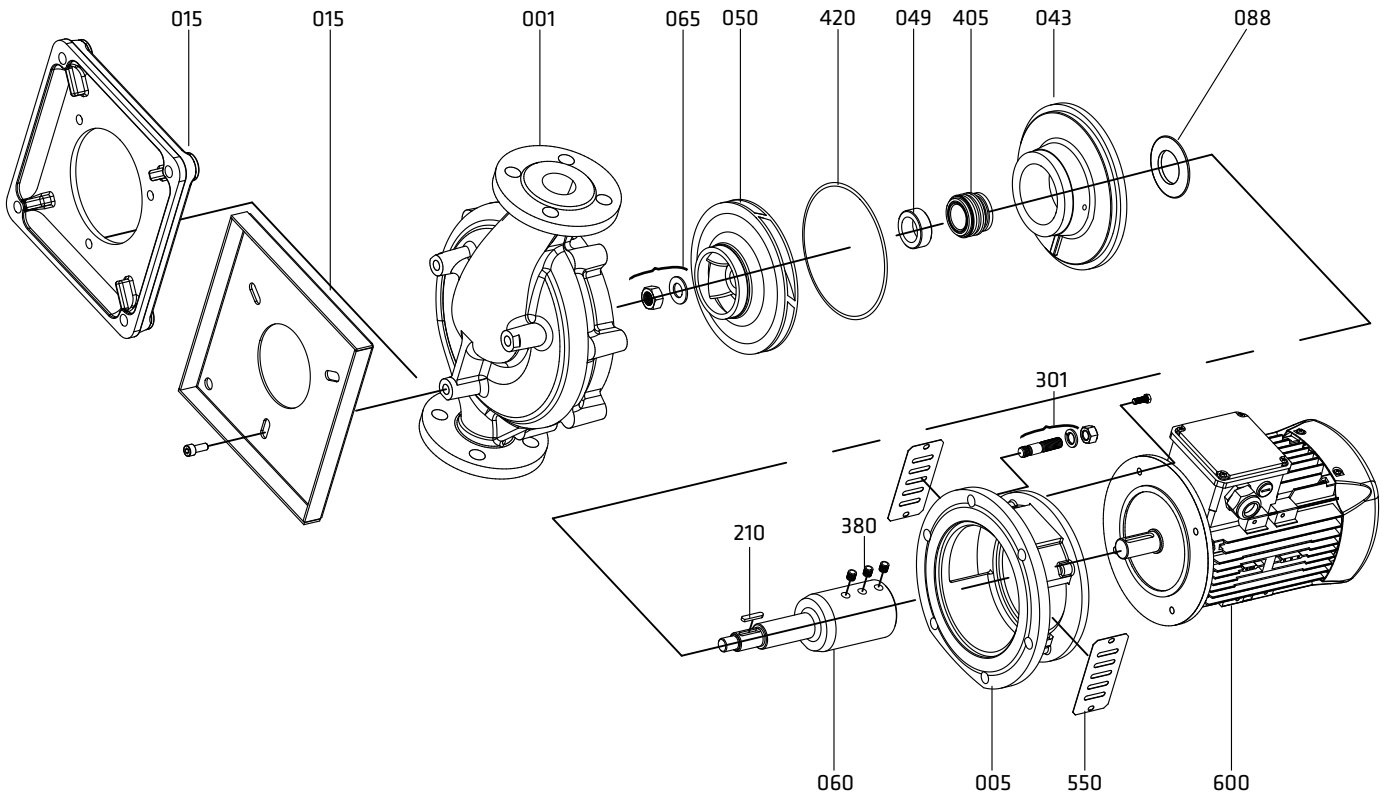

Form: F2 (Slide - fit shaft application)

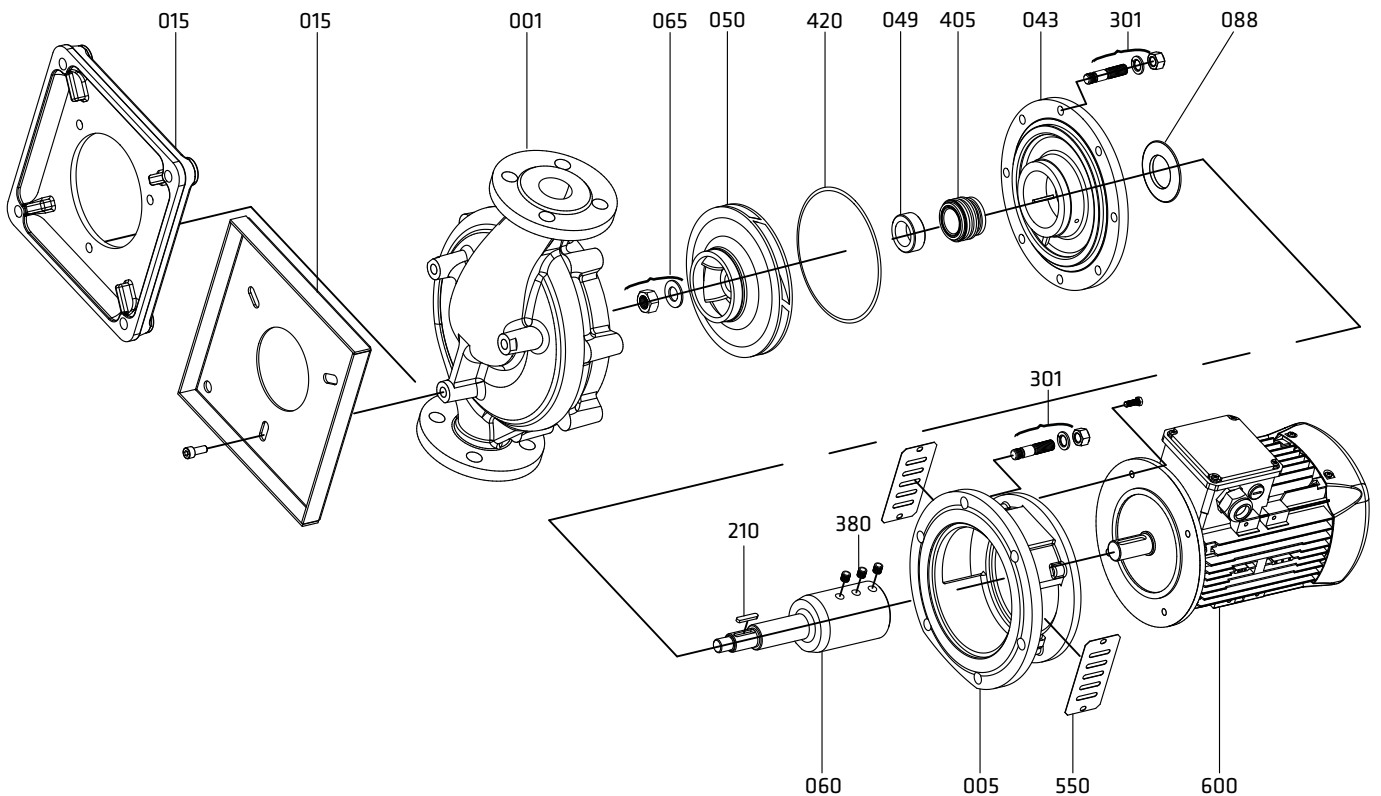

Rigid Coupling Application

For motor shaft diameters of Ø60 mm or bigger.

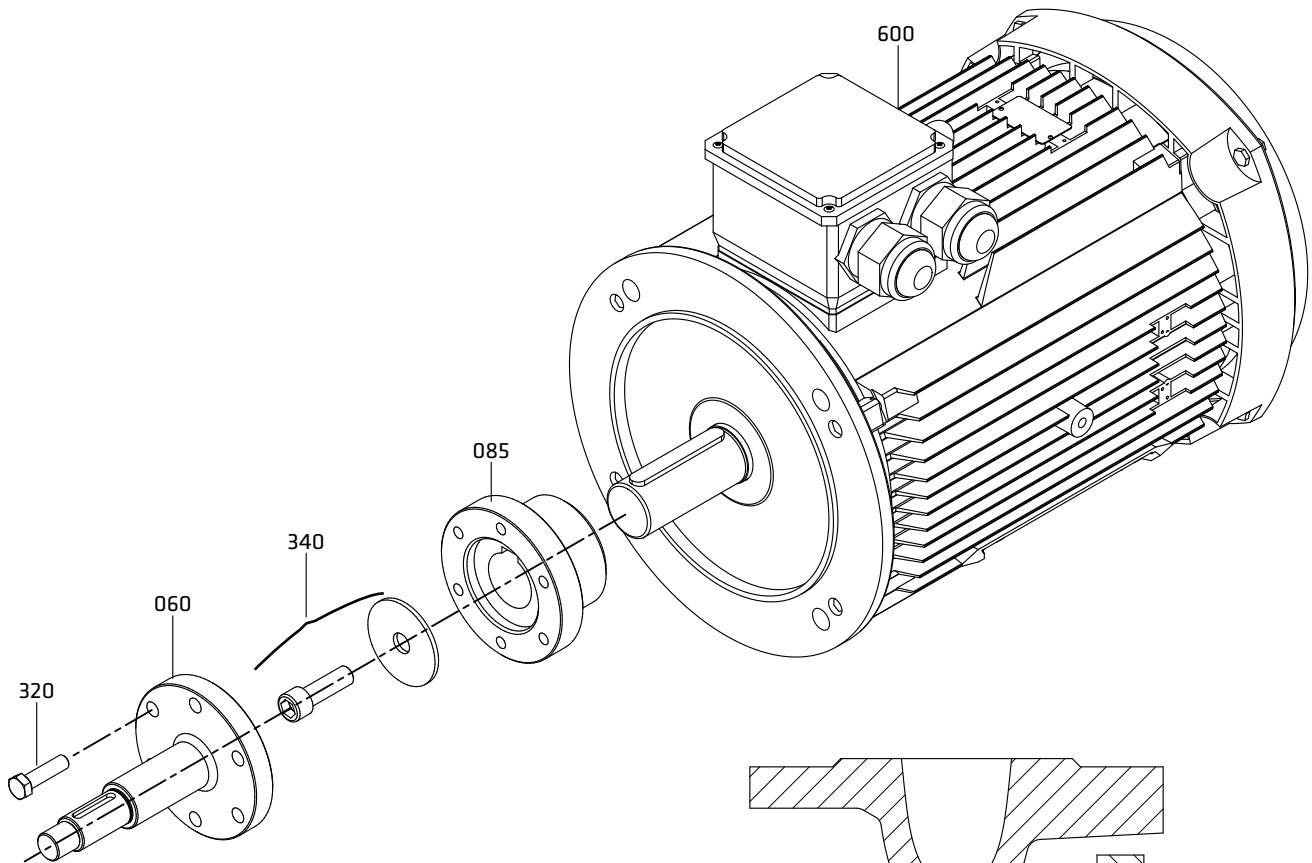

Part List

001	Volute Casing
005	Motor Pedestal
015	Bottom Plate
020*	Wear Ring (casing)
021*	Wear Ring (seal cover)
043	Mechanical Seal Cover
049	Mechanical Seal Spacer Sleeve
050	Impeller
060	Shaft
065	Impeller Nut and Washer
088	Thrower
093	Rigid Coupling
210	Impeller Key
230	Screw
301	Stud, Washer and Nut
320	Screw
340	Allen Screw and Washer
380	Set Screw
405	Mechanical Seal
420	O-ring
550	Guard
600	Electric Motor

(*) Optional

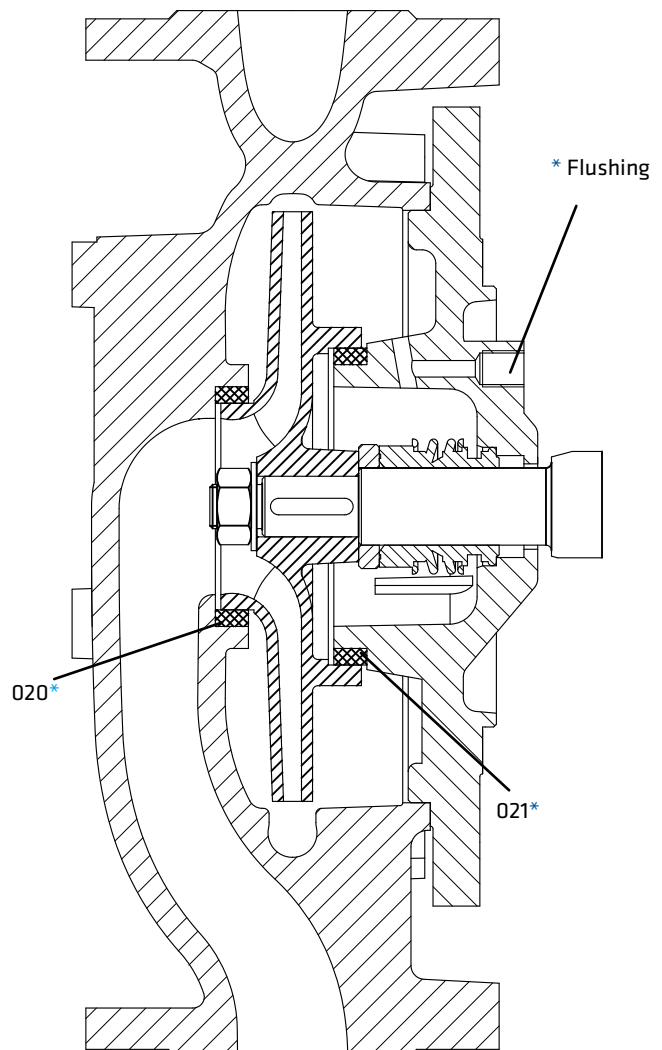

Installation Arrangements

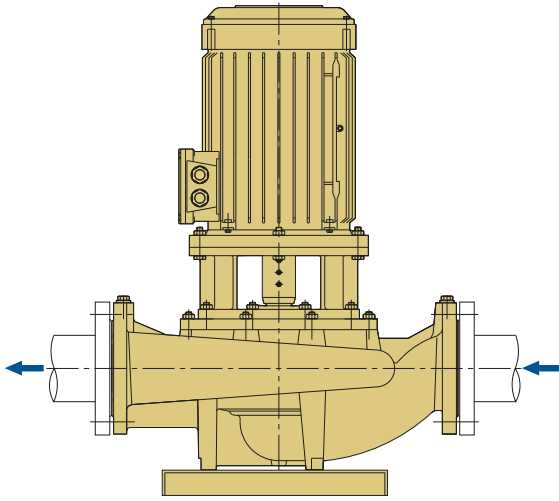

Standard installation type to horizontal pipe. (on ground)

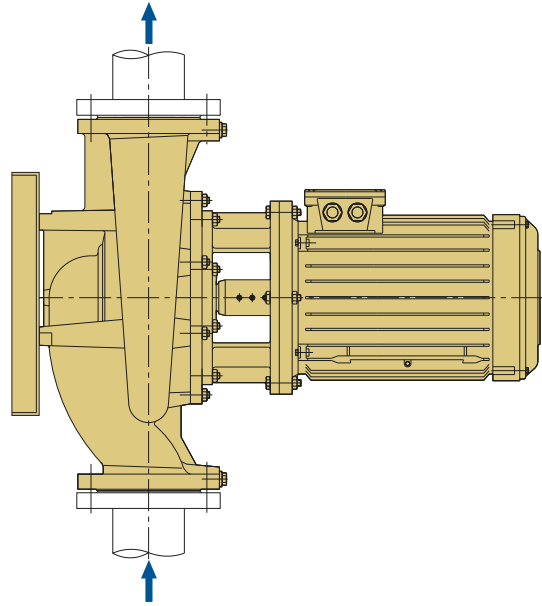

Please consult to Dynapumps in case of installation to vertical pipes.

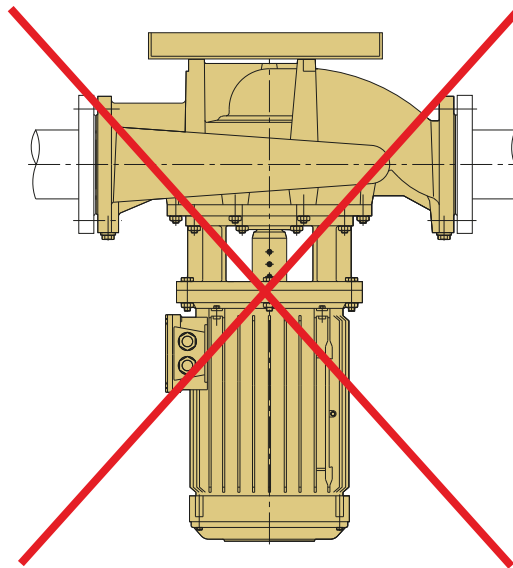

The axis of motor below the horizontal line is not admissible.

Technical Data

PART LIST	10	30	35	20	60	6L	70	7L	8M	7D	7S	8N	80	4C	4A	40	80	8T	60	7L	7E	7D	
	0.6025	0.7040	0.7043	1.0619	1.4308	1.4309	1.4408	1.4409	1.4500	1.4517	1.4469	1.4317	1.4008	2.1050.01	2.0975.01	2.1096.01	1.4021	1.4021+QT	1.4301	1.4404	1.4460	1.4462	
Volute Casing	●	○	○	○	○	○	○	○	○	○	○	○	○	○	○	○	○	○	○	○	○	○	○
Mechanical Seal Cover	●	○	○	○	○	○	○	○	○	○	○	○	○	○	○	○	○	○	○	○	○	○	○
Impeller	●	○	○	○	○	○	○	○	○	○	○	○	○	○	○	○	○	○	○	○	○	○	○
Shaft																	●	○	○	○	○	○	○
Motor Pedestal	●	○	○	○	○	○	○	○															
Wear Ring	○	○	○	○	○	○	○	○	○	○	○	○	○	○	○	○	○	○	○	○	○	○	○
Mech Seal Spacer Sleeve																	●	○	○	○	○	○	○
Mechanical Seal (*)	EN 12756																						
Bottom Plate	According to pump types, steel or cast iron material can be used. Contact company for non-standard application.																						

(*) Optional :Depending on customer requirement or request different types and brands of mechanical seals are applicable.

● Standard manufacturing

NOTE: Depends on the request, different than above casting and shaft material can be supplied.

○ Optional

Material Equivalents

TANIM	DIN / EN	AISI / SAE / ASTM	
Cast Iron	0.6025	EN-GJL-250 (GG25)	A48 Class 40B
Nodular Cast Iron	0.7040	EN-GJS-400-15 (GGG40)	A536 60-40-18
Nodular Cast Iron	0.7043	EN-GJS-400-18-LT (GGG40.3)	A536 60-40-18
Cast Steel	1.0619	GP240GHGS-C25	A216 WCB
Chrome Nickel Cast Steel	1.4308	GX5CrNi19-10	A351 CF8
Chrome Nickel Cast Steel (low carbon)	1.4309	GX2CrNi19-11	A351 CF3
Chrome Nickel Molybdenum Cast Steel	1.4408	GX5CrNiMo19-11-2	A351 CF8M
Chrome Nickel Molybdenum Cast Steel (low carbon)	1.4409	GX2CrNiMo19-11-2	A351 CF3M
Austenitic Cast Steel	1.4500	GX7NiCrMoCuNb25-20	A351 CN7M
Austenitic - Ferritic Cast Steel (duplex)	1.4517	GX2CrNiMoCuN25-6-3-3	A890 CD4MCuN
Austenitic - Ferritic Cast Steel (super duplex)	1.4469	GX2CrNiMoN26-7-4	A890 CE3MN
Martenzitic Stainless Cast Steel	1.4317	GX4CrNi13-4	A352 CA6NM
Martenzitic Stainless Cast Steel	1.4008	GX7CrNiMo12-1	A217 CA15
Cast Bronze (tin alloy)	2.1050.01	G-CuSn10	B427 C90700
Cast Bronze (nickel alloy)	2.0975.01	G-CuAl10Ni	B148 C95500
Cast Bronze (Leaded)	2.1096.01	G-CuSn5ZnPb	B584 C83600
Chrome Steel	1.4021	X20Cr13	A276 Type 420
Chrome Steel(heat treated)	1.4021	X20Cr13	A276 Type 420+QT
Chrome Nickel Steel	1.4301	X5CrNi18-10	A276 Type 304
Chrome Nickel Steel (low carbon)	1.4404	X2CrNiMo17-12-2	A276 Type 316L
Duplex (austenitic-ferritic) Steel	1.4460	X3CrNiMoN27-5-2	AISI 329
Duplex (austenitic-ferritic) Steel	1.4462	X2CrNiMoN22-5-3	UNS S32205

Flange Dimensions

EN 1092 - 2	DNe/DNb	Suction & Discharge (PN 16)			
		Df	k	s	n
	40	150	110	19	4
	50	165	125	19	4
	65	185	145	19	4
	80	200	160	19	8
	100	220	180	19	8
	125	250	210	19	8
	150	285	240	23	8
	200	340	295	23	12

“ n “ number of holes