

# HW-E

## MULTISTAGE PUMPS (END SUCTION)



### Handled Liquids

Clean or slightly contaminated low viscosity liquids without solid & fibrous particles.

### Technical Data

Discharge Flange \_\_\_\_\_ DN 40.....DN 150 mm

Capacity \_\_\_\_\_ up to 400 m<sup>3</sup>/h

Head \_\_\_\_\_ up to 450 m

Speed \_\_\_\_\_ up to 2900 rpm

Operating Temperature \_\_\_\_\_ -10 °C up to +140 °C (\*)

Casing Pressure (Pmax) \_\_\_\_\_ 30 bar (63 bar) (\*)

(Pmax: Suction Pressure + Shut off Head)

(\*) The Material of pumps differ according to the type of pumped liquid, operating temperature and pressure. Contact for detailed information.

### Design Features

- Horizontal ring section, multistage, centrifugal pumps with closed impellers and diffusers in end suction design.
- 7 Models from DN 40 up to DN 150 discharge flange diameter.
- Suction nozzle flanges conform to EN 1092 - 2 / PN 16 and discharge nozzle flanges conform to EN 1092 - 2 / PN 40 (PN 63) (For steel or stainless steel casing pumps, flanges conform to related pressure class ratings defined in EN 1092 - 1)

### Pump Designation

Pump Type \_\_\_\_\_

Discharge Nozzle (DN-mm) \_\_\_\_\_

Number of Stages \_\_\_\_\_

**HW-E 100 / 6**

- Discharge flange is on top for standard production, upon request different discharge flange positions can be applied.
- All impellers are balanced dynamically or statically according to ISO 1940 class 6.3.
- Axial thrust is balanced by impeller balancing holes system.
- Direction of rotation is always counter clockwise viewed from drive end. That's why these pumps can not be accoupled directly with diesel engines.
- Bearings of HW-E type pumps are grease lubricated. Sleeve bearing used in the suction side is lubricated by the pumping liquid.

### Shaft Sealing

- In standard production soft packing application is applied up to 110 °C. Between 110 °C and 140 °C soft packing may also applied together with the stuffing box cooling.
- Pumps with mechanical seal can also be manufactured upon request.

Field Chart

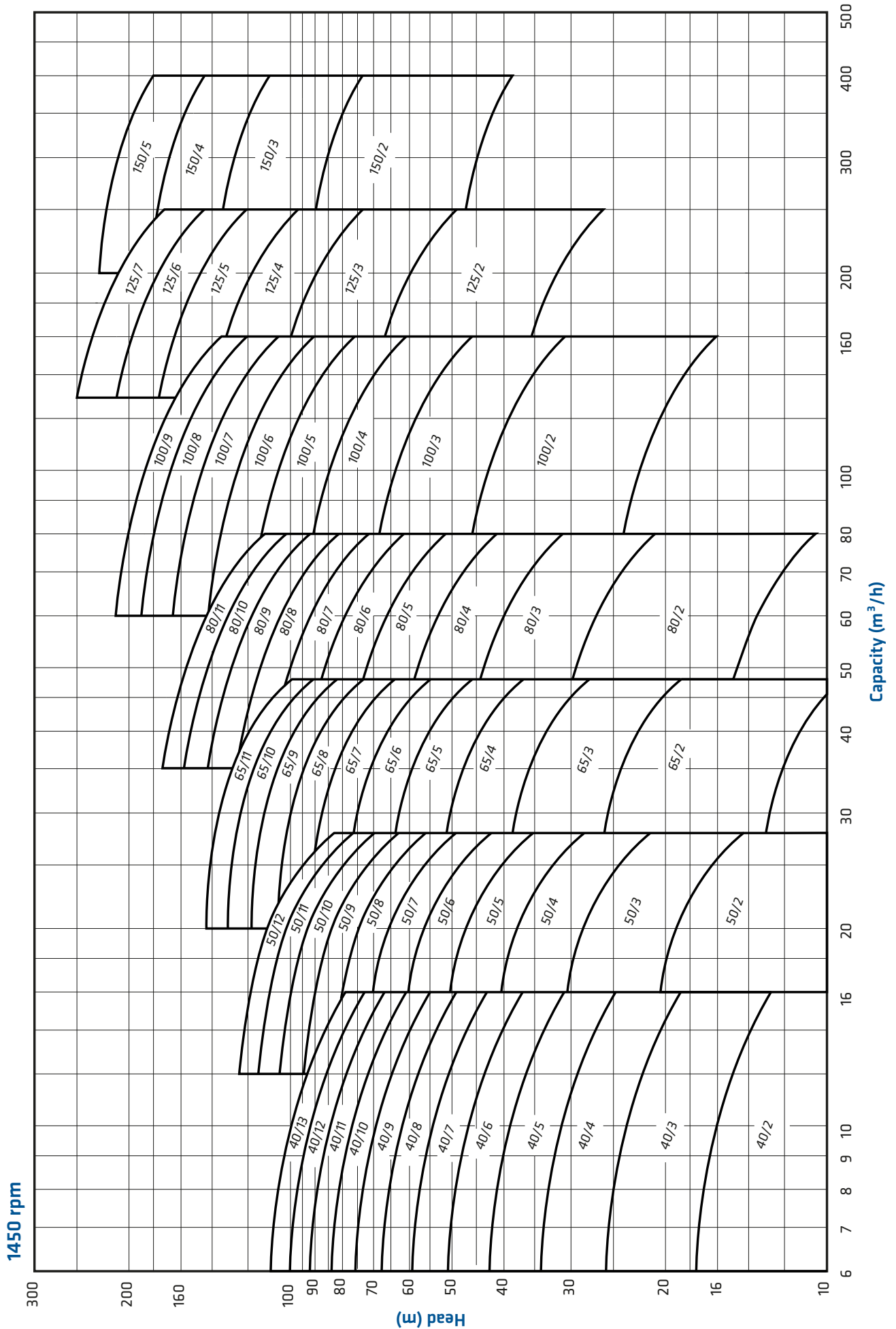

Field Chart

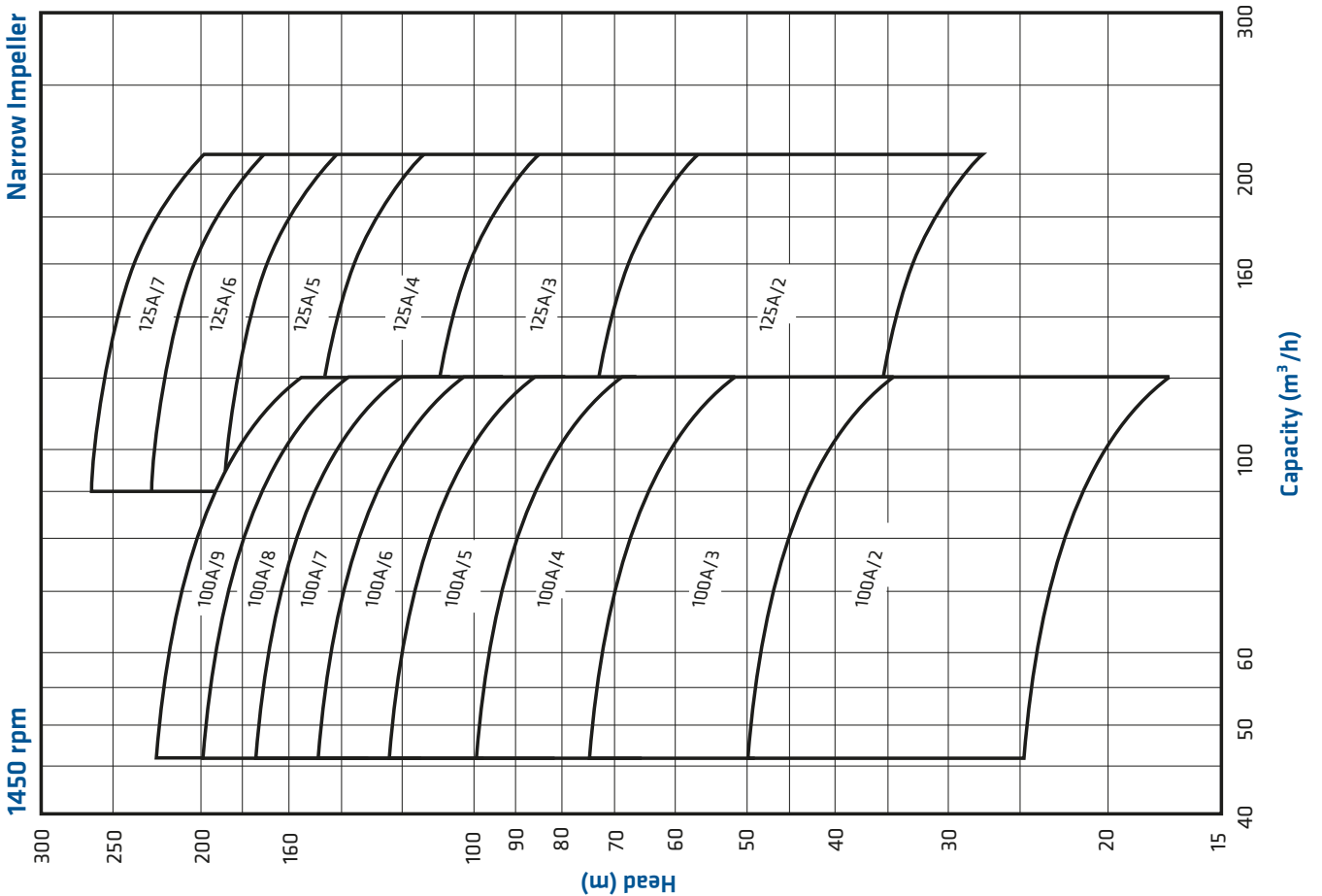
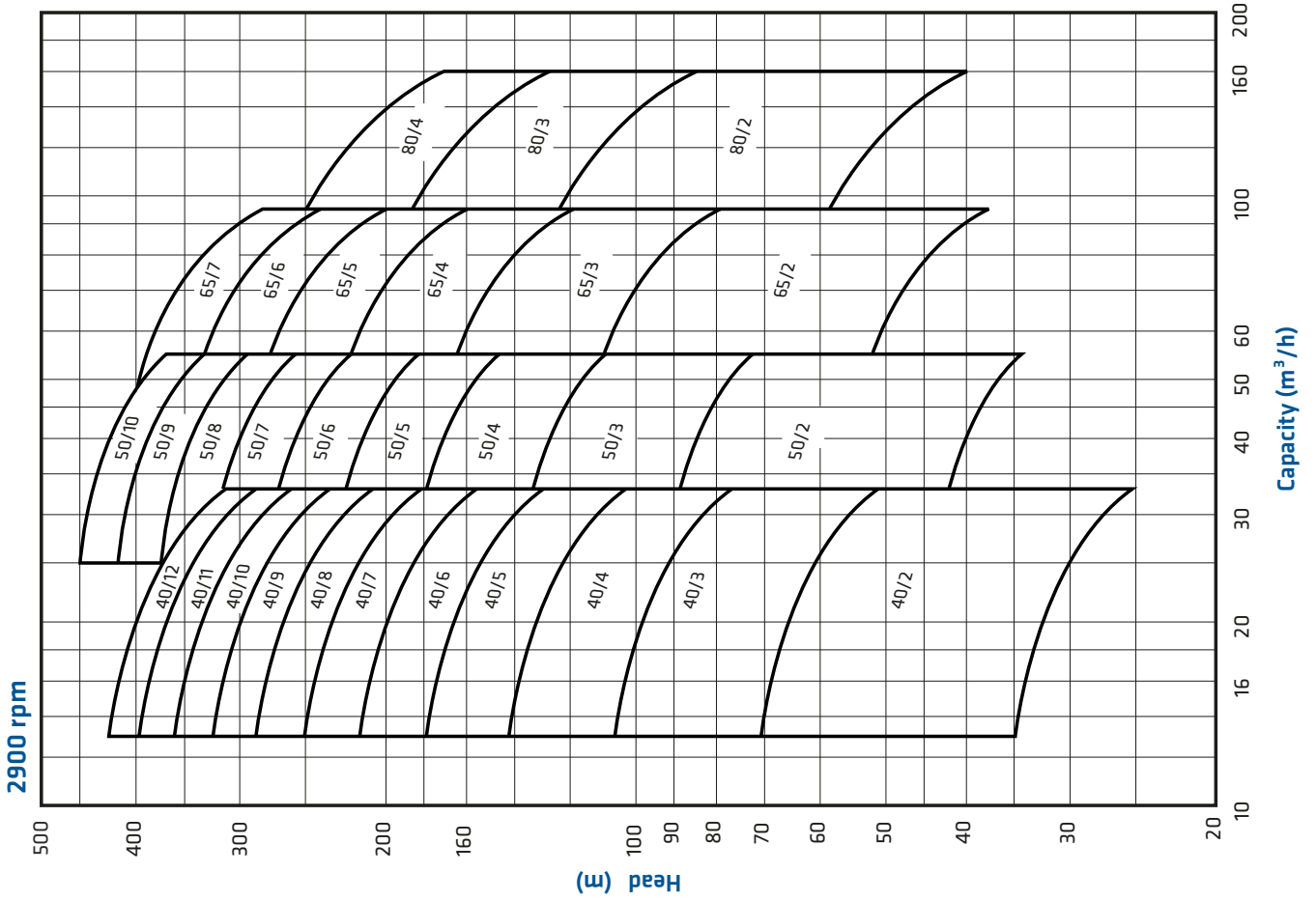

Field Chart

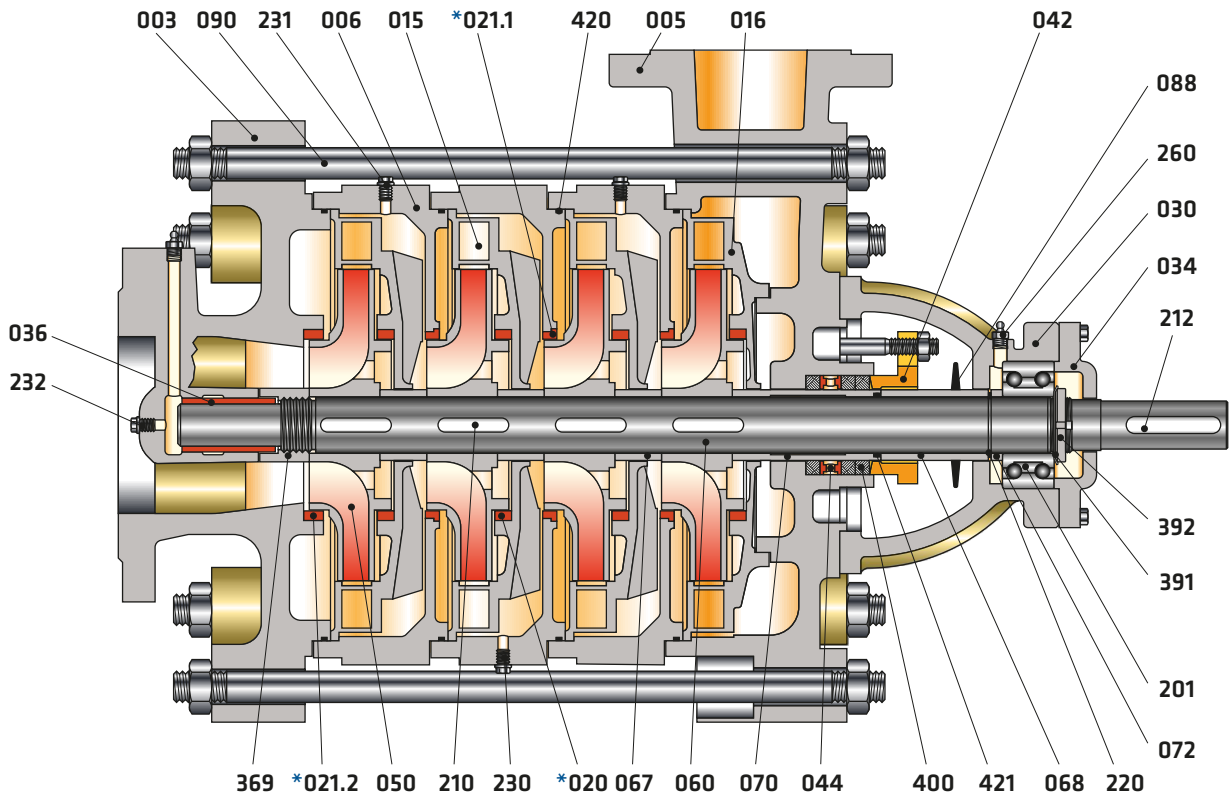

Part List

003	Suction Casing	*074	Shaft Sleeve (mechanical seal)
005	Discharge Casing	088	Thrower
006	Stage Casing	090	Tiebolt
015	Diffuser	201	Double Row Ball Bearing
016	Last Stage Diffuser	210	Impeller Key
*020	Wear Ring (diffuser)	212	Coupling Key
*021.1	Wear Ring (stage casing)	220	Retaining Ring
*021.2	Wear Ring (suction casing)	230	Drain Plug
030	Bearing Housing	231	Filling Plug
034	Bearing Cover	232	Plug
036	Sleeve Bearing	260	Grease Nipple
042	Stuffing Box Gland	369	Shaft Nut
044	Lantern Ring	391	Lock Washer
*048	Mechanical Seal Cover	392	Shaft Nut
050	Impeller	400	Soft Packing
060	Shaft	*405	Mechanical Seal
067	Interstage Sleeve	420	O-Ring
068	Spacer Sleeve (discharge side)	421	O-Ring
070	Shaft Sleeve (soft packing)	*422	O-Ring
072	Spacer Sleeve (bearing)		

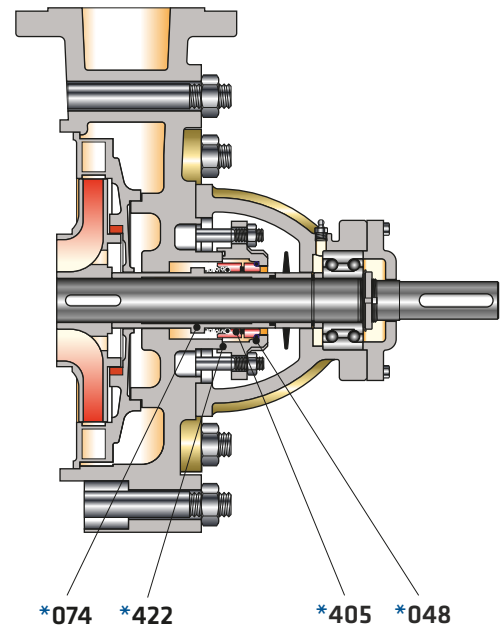

\* Optional

## Technical Data

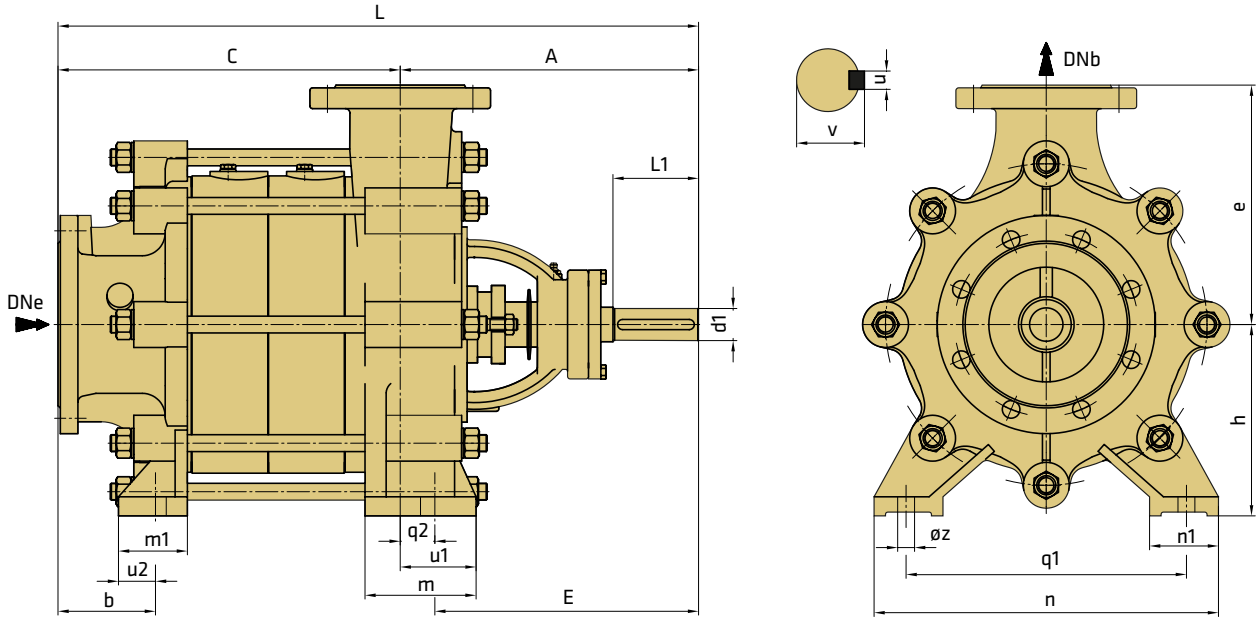

"C" according to the number of stages (mm)												
Pump Type	2	3	4	5	6	7	8	9	10	11	12	13
40	187	242	297	352	407	462	517	572	627	682	737	792
50	212	274	336	398	460	522	584	646	708	770	832	
65	247	318	389	460	531	602	673	744	815	886		
80	280	363	446	529	612	695	778	861	944	1027		
100	347	447	547	647	747	847	947	1047				
125	364	479	594	709	824	939						
150	437	582	727	872								

Maximum number of stages according to shaft material				
Pump Type	1.4462 / 1.4021		1.4301 / 1.4401	
	1450 rpm	2900 rpm	1450 rpm	2900 rpm
40	1750 rpm	3500 rpm	1750 rpm	3500 rpm
40	13(13)	12(8)	13(13)	7(3)
50	12(12)	10(6)	12(10)	7(2)
65	11(11)	7(4)	11(8)	5(2)
80	11(11)	4(2)	11(8)	3(N/A)
100	9(7)	-	6(4)	-
125	7(5)	-	4(2)	-
150	5(3)	-	3(N/A)	-

Bearing Type	
Pump Type	Bearing Type
40	6305
50	6306
65	6307
80	3308
100	3309
125	3310
150	3312

Pump Type	Dimensions (mm)																	Shaft				Weight (kg)	
	DNe	DNb	A	b	L	E	e	h	m	m1	n	n1	q1	q2	øz	u1	u2	d1	l1	v	u	G	g
40	65	40	237	23	C+237	147	175	160	60	75	232	55	175	90	15	109	20	24	60	27	8	54	9,5
50	80	50	258	23	C+259	160	190	160	60	85	256	60	200	98	15	115	20	28	65	31	8	82	13
65	100	65	275	38	C+275	170	215	180	60	85	294	60	240	121	15	125	25	32	65	35	10	85	20
80	125	80	331	75	C+331	289	265	210	85	85	410	90	340	42	15	62	25	38	80	41	10	113	26
100	150	100	397	105	C+397	349	300	250	90	90	450	90	370	48	15	70	30	42	110	45	12	150	42
125	200	125	410	70	C+410	355	375	300	110	112	572	105	450	55	23	80	30	48	110	51,5	14	264	75
150	200	150	475	60	C+475	410	425	350	130	135	655	110	550	65	23	103	30	55	110	59	16	455	120

Note: All rights reserved.

Pump weight= G + (s x g) (s: number of stage)

## Flange Dimensions

EN 1092 - 2	DNe/DNb	Suction & Discharge (PN 16)				Suction & Discharge (PN 40)			
		Df	k	s	n	Df	k	s	n
	40	150	110	19	4	150	110	19	4
	50	165	125	19	4	165	125	19	4
	65	185	145	19	4	185	145	19	8
	80	200	160	19	8	200	160	19	8
	100	220	180	19	8	235	190	23	8
	125	250	210	19	8	270	220	28	8
	150	285	240	23	8	300	250	28	8
	200	340	295	23	12	375	320	31	12

"n" number of holes

## Technical Data

Part List	0.6025	0.7040	0.7043	1.0619	1.4308	1.4309	1.4408	1.4409	1.4500	1.4517	1.4469	1.4317	1.4008	2.1050.01	2.0975.01	2.1096.01	1.0503	1.4021	1.4021+QT	1.4301	1.4404	1.4460	1.4462	Tungsten Carbide	
Suction Casing	●	○	○		○	○	○	○	○	○	○	○	○	○											
Discharge Casing	●	○	○		○	○	○	○	○	○	○	○	○	○											
Stage Casing	●	○	○		○	○	○	○	○	○	○	○	○	○											
Diffuser	●	○	○	○	○	○	○	○	○	○	○	○	○	○	○	○									
Impeller	●	○	○	○	○	○	○	○	○	○	○	○	○	○	○	○							○		
Shaft																		●	○	○	○			○	
Bearing Housing	●	○	○	○	○	○	○	○																	
Wear Ring	○	○	○	○	○	○	○	○	○	○	○	○	○	○	○	○									
Spacer Sleeve																	●	○	○	○	○			○	
Shaft Sleeve																	●	○	○	○	○			○	
Interstage Sleeve																	●	○	○	○	○			○	
Sleeve Bearing														●										○	
Mechanical Seal (*)	EN 12756																								

(\*) Optional :Depending on customer requirement or request different types and brands of mechanical seals are applicable. ● Standard manufacturing ○ Optional

## Material Equivalents

Description	DIN / EN		AISI / SAE / ASTM
Cast Iron	0.6025	EN-GJL-250 (GG25)	A48 Class 40B
Nodular Cast Iron	0.7040	EN-GJS-400-15 (GGG40)	A536 60-40-18
Nodular Cast Iron	0.7043	EN-GJS-400-18-LT (GGG40.3)	A536 60-40-18
Cast Steel	1.0619	GP240GHGS-C25	A216 WCB
Chrome Nickel Cast Steel	1.4308	GX5CrNi19-10	A351 CF8
Chrome Nickel Cast Steel (low carbon)	1.4309	GX2CrNi19-11	A351 CF3
Chrome Nickel Molybdenum Cast Steel	1.4408	GX5CrNiMo19-11-2	A351 CF8M
Chrome Nickel Molybdenum Cast Steel (low carbon)	1.4409	GX2CrNiMo19-11-2	A351 CF3M
Austenitic Cast Steel	1.4500	GX7NiCrMoCuNb25-20	A351 CN7M
Austenitic - Ferritic Cast Steel (duplex)	1.4517	GX2CrNiMoCuN25-6-3-3	A890 CD4MCuN
Austenitic - Ferritic Cast Steel (super duplex)	1.4469	GX2CrNiMoN26-7-4	A890 CE3MN
Martenzitic Stainless Cast Steel	1.4317	GX4CrNi13-4	A352 CA6NM
Martenzitic Stainless Cast Steel	1.4008	GX7CrNiMo12-1	A217 CA15
Cast Bronze (tin alloy)	2.1050.01	G-CuSn10	B427 C90700
Cast Bronze (nickel alloy)	2.0975.01	G-CuAl10Ni	B148 C95500
Cast Bronze (lead)	2.1096.01	G-CuSn5ZnPb	B584 C83600
Carbon Steel	1.0503	C45	AISI 1045
Chrome Steel	1.4021	X20Cr13	A276 Type 420
Chrome Steel (heat treated)	1.4021	X20Cr13	A276 Type 420+QT
Chrome Nickel Steel	1.4301	X5CrNi18-10	A276 Type 304
Chrome Nickel Steel (low carbon)	1.4404	X2CrNiMo17-12-2	A276 Type 316L
Duplex (austenitic-ferritic) Steel	1.4460	X3CrNiMoN27-5-2	AISI 329
Duplex (austenitic-ferritic) Steel	1.4462	X2CrNiMoN22-5-3	UNS S32205

## Flange Positions

Direction of rotation is counter clockwise viewed from driver end.  
(Discharge flange is on motor side)

Explanation:  
**L/O**



Viewed from drive end.  
**L:** Left

