

**SUBMERSIBLE**  
**ENCAPSULATED**

# MOTORS



Dynapumps Offices Australia & Chile

**Dynapumps**  
MORE THAN JUST PUMPS

6" ENCAPSULATED  
SUBMERSIBLE MOTORS

CATALOGUE



**ENM T**  
Encapsulated Submersible Motor

6"

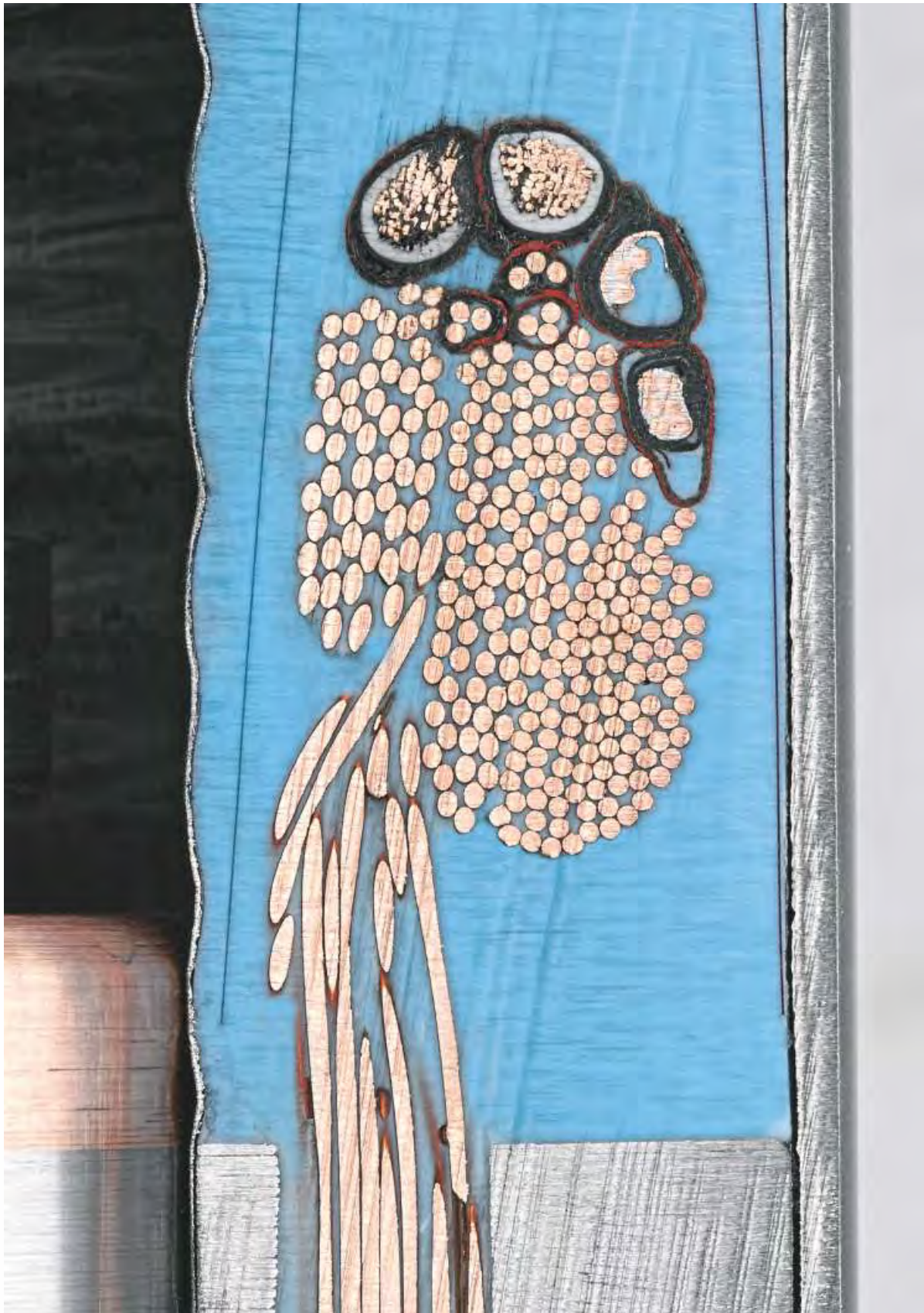

**ENMOT SUBMERSIBLE MOTOR SECTION**



**6" ENCAPSULATED  
SUBMERSIBLE MOTORS** **50/60 HZ**

# Superior Dynapumps Motors





## 6" ENCAPSULATED SUBMERSIBLE MOTORS

Water cooled motors with encapsulated resin filled stator.

Coupling dimensions and flange according to NEMA standard.

### General Features

- ▶ 5,5-60 HP / 3PH. 380-415 Volts / 50Hz
- ▶ High efficiency provides operation cost savings
- ▶ Motor casing and shaft made of AISI304L stainless steel (Optional AISI316L)
- ▶ High resistance coated cast iron upper and lower bracket (Optional AISI304L / AISI316L)
- ▶ Water lubricated Kingsbury type thrust bearings
- ▶ Protection IP68
- ▶ Sand slinger protection
- ▶ Pressure equalizing diaphragm
- ▶ Insulation class F
- ▶ Removable lead cable
- ▶ Starting method D.O.L. and star/delta

### Operating Limits

- ▶ Max. voltage fluctuation:  $\pm 10\%$
- ▶ Max. water temperature: 35°C with at least 0.16 m/s of water flow speed
- ▶ Max. motor startings per hour: 20
- ▶ Max. immersion depth: 350 m
- ▶ Standard mounting position: vertical and horizontal





**Slinger (sand guard)**

Slinger helps to prevent the sand inside the water of the well entering in mechanical seal and through mechanical seal to inside of the motor.



**High thrust capacity**

Heavy duty bearings provides the option to revolve both sides, has the capacity to carry high thrust load.



**Adjustment screw**

Standard shaft height can be precisely adjusted by the adjustment screw on the thrust bearing base.



**Up-Thrust ring**

Provides safe operation conditions for motor by absorbing Up-Thrust loads with it's machined surface and water channels on it.





### Practical cable connection

Extremely simple and very practical power cable connection to the motor body.



### Water lubricated radial carbon bearings

Radial carbon bearings, which have channels in its structure that makes it possible to get lubricated by water easily, provides precise bearing of rotor shaft at up and down.



### High quality mechanical sealing system

High sand resistance and degree of IP68 protection. Although mechanical seal is optionally used by other companies, it is always used by Dynapumps as a standard, to prevent sand and other particles to get in motors to provide long bearing life.



### Pressure balancing checkvalve

When the pressure increases, it throw water out of the motor. When the pressure drops, it filtrates the water inside well and gets it inside the motor by the help of this checkvalve to balance the pressure inside. That's why pressure differences inside motor never causes membrane under motor to blow up.



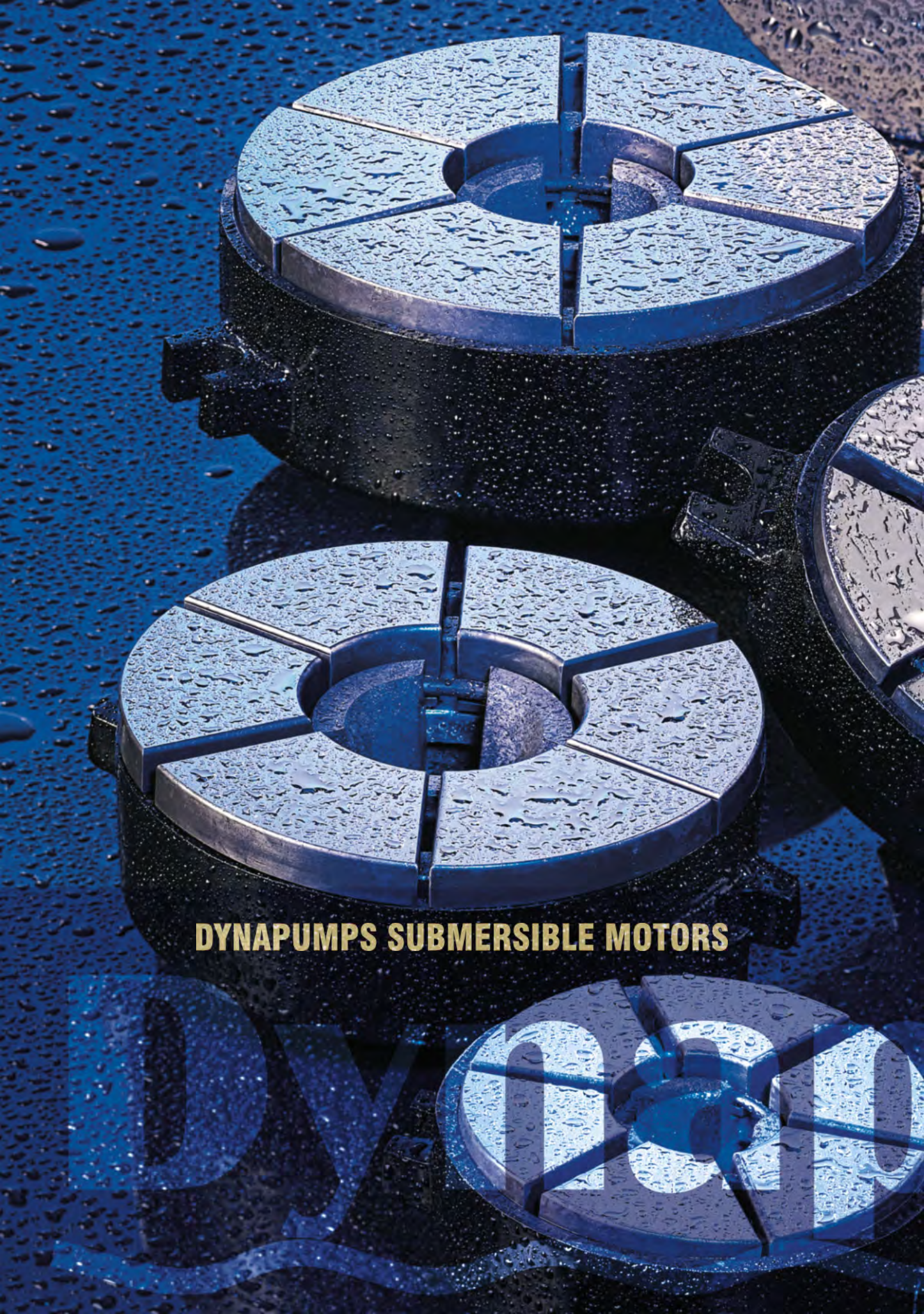

**DYNAPUMPS SUBMERSIBLE MOTORS**

**DYNAPUMPS**





**Dynapumps**  
MORE THAN JUST PUMPS

## Product Code System

### FSME 6 / 4 - 3PH . F50 . V380 - DCX

Mech. Seal (X: Ceramic Carbon, Y: SiC/SiC )  
 Casting (C: GG25, S: AISI304, N: AISI316)  
 Starting (D: DOL, S: Star/Delta)  
 Voltage Value  
 Frequency (50Hz, 60Hz)  
 Phase Type  
 Motor Power (kW)  
 Product Type

## Part List

No	Part Name	Material
1	Stator	-
1.1	Winding wire	Copper
1.2	Stator package	M350 / Magnetic Seal
1.3	Stator shell	AISI 304
2	Rotor	-
2.1	Shaft sleeve	Coated CrNi
2.2	Balance ring	St 37
2.3	Copper ring	Cu
3	Radial bearing	Carbon
4	Upper bearing body	GG20-22
5	Bushing	Bronze
6	Slinger (sand guard)	NBR_EPDM
7	Hexagon socket cap screws	Inox
8	Copper ring	Cu
9	Cover seal	AISI 420
10	Mechanical seal	Ceramic Carbon
11	Axial thrust bearing key	AISI 420
12	Axial thrust bearing	Carbon With Antimony
13	Retaining ring	St 37
14	Tie rod	Inox
16	Thrust bearing support	GG20-22
17	Ball holder	St 37 (Coated Cr+3)
18	Thrust bearing ball	Inox
19	Tilting pads	AISI 420
20	O-ring	NBR 70
21	Thrust bearing body	GG20
23	Nut	Inox
24	Screw (thrust bearing base)	Inox
25	Membrane	NBR-EPDM
26	Membrane body	GG22
27	Hexagon socket cap screws	Inox
28	Check-valve	Bronze
29	O-ring	NBR 70
30	Cable seal	NBR
31	Seal cover	AISI 304
32	Nut	Inox
33	Plush (r 3/8")	Bronze
34	Ball holder pins	Inox

**Technical Drawing**

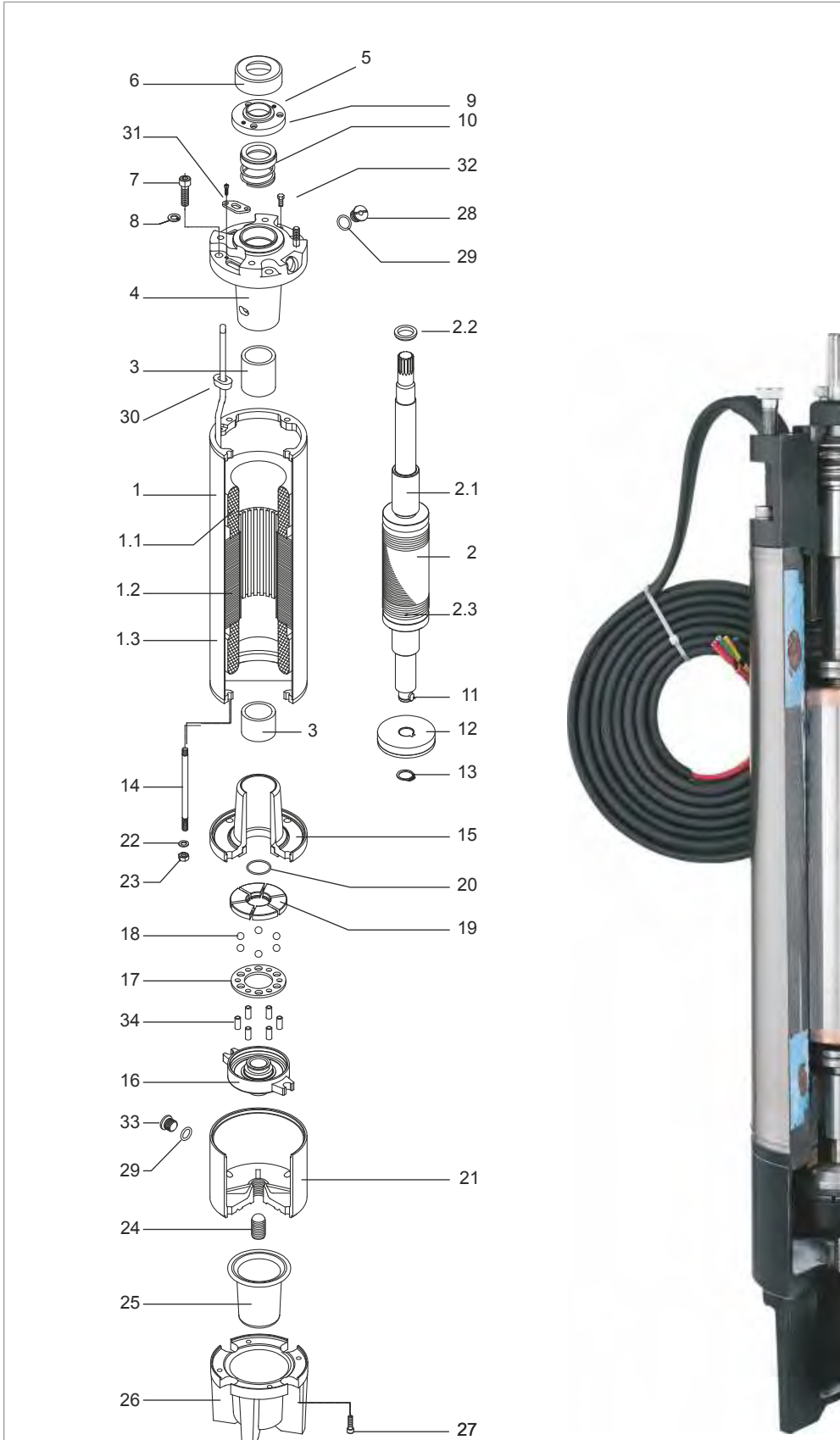

Type	P <sub>N</sub>		Axial Load kN	Voltage V	n <sub>N</sub> rpm	I <sub>N</sub> A	I <sub>A</sub> A	Efficiency (% load)			Cos Φ (% load)			TN Nm	TA Nm	Motor Length mm	Motor Weight Kg
	HP	kW						50	75	100	50	75	100				
FSME 6/4-3ph.f50.V380-DCX	5,5	4	20	380	2850	9,2	34,0	78,5	80,3	79,0	0,75	0,82	0,83	13,4	18,0	578	42
FSME 6/5.5-3ph.f50.V380-DCX	7,5	5,5	20	380	2770	12,4	48,0	78,5	80,3	78,3	0,80	0,83	0,86	18,8	28,7	598	44
FSME 6/7.5-3ph.f50.V380-DCX	10	7,5	20	380	2840	16,5	69,0	77,7	80,5	80,2	0,76	0,83	0,86	25,0	44,2	653	50,5
FSME 6/9.3-3ph.f50.V380-DCX	12,5	9,3	20	380	2840	20,3	94,6	79,6	81,8	80,5	0,76	0,83	0,87	31,2	56,0	681	53
FSME 6/11-3ph.f50.V380-DCX	15	11	20	380	2840	23,6	90,0	80,3	82,6	81,0	0,77	0,82	0,87	37,0	70,0	718	57
FSME 6/13-3ph.f50.V380-DCX	17,5	13	20	380	2860	27,6	145,2	79,8	82,3	81,5	0,80	0,84	0,87	43,5	85,0	753	60,5
FSME 6/15-3ph.f50.V380-DCX	20	15	20	380	2845	32,1	181,0	80,1	82,6	81,5	0,79	0,85	0,87	50,3	98,0	798	65,5
FSME 6/18.5-3ph.f50.V380-DCX	25	18,5	20	380	2860	40,5	246,0	79,4	82,3	82,0	0,77	0,82	0,85	61,6	137	858	72,5
FSME 6/22-3ph.f50.V380-DCX	30	22	20	380	2850	47,5	279,0	81,2	83,2	82,2	0,78	0,84	0,86	73,6	157	898	75,5
FSME 6/26.5-3ph.f50.V380-DCX	35	26,5	26	380	2850	57,9	338,0	81,7	83,7	82,5	0,76	0,81	0,84	88,7	193	983	88
FSME 6/30-3ph.f50.V380-DCX	40	30	26,5	380	2870	64,5	412,0	80,2	82,9	83,0	0,77	0,83	0,85	99,2	239	1063	92
FSME 6/37-3ph.f50.V380-DCX	50	37	26,5	380	2860	80,0	478,0	80,3	82,8	83,0	0,75	0,81	0,85	124	248	1198	95
FSME 6/45-3ph.f50.V380-DCX	60	45	26,5	380	2850	96,5	520,0	81,6	83,7	83,0	0,77	0,83	0,85	151	286	1273	98

# FSME 6 (3ph-50 Hz)

Motor Power Range **5,5 HP - 60 HP**

Thrust Load Capacity **5,5 HP - 30 HP = 20,0 kN**  
**35,0 HP - 60 HP = 26,5 kN**

Outside Diameter **142 mm**

Flange Standard **6" NEMA Standard**

*Due to continuous improvement in design we reserve the right to amend specifications or data without prior notice.*



Type	P <sub>N</sub>		Axial Load kN	Voltage V	n <sub>N</sub> rpm	I <sub>N</sub> A	I <sub>A</sub> A	Efficiency (% load)			Cos Φ (% load)			TN Nm	TA Nm	Motor Length mm	Motor Weight Kg
	HP	kW						50	75	100	50	75	100				
FSME 6/4-3ph.f60.V460-DCX	5,5	4	20	460	3470	7,8	32,0	71.1	75.9	77.7	0.73	0.79	0.83	10,9	18,1	578	42
				380	3465	9,4	38,7	71.1	75.9	77.7	0.73	0.79	0.83	11,0	18,4		
				220	3455	16,3	66,9	70.0	75.0	77.0	0.73	0.79	0.83	11,2	19,0		
FSME 6/5.5-3ph.f60.V460-DCX	7,5	5,5	20	460	3430	9,8	52,5	73.5	78.6	80.0	0.79	0.83	0.88	15,2	29,2	598	44
				380	3425	11,9	63,6	73.5	78.6	80.0	0.79	0.83	0.88	15,3	29,5		
				220	3415	20,5	109,8	72.5	77.5	79.0	0.79	0.83	0.88	15,5	30,1		
FSME 6/7.5-3ph.f60.V460-DCX	10	7,5	20	460	3460	14,2	75,0	69.6	75.6	78.1	0.74	0.81	0.85	20,5	44,8	653	50,5
				380	3455	17,2	90,8	69.6	75.6	78.1	0.74	0.81	0.85	20,6	45,1		
				220	3445	29,7	156,8	69.0	74.7	77.1	0.79	0.83	0.88	20,8	45,7		
FSME 6/9.3-3ph.f60.V460-DCX	12,5	9,3	20	460	3480	16,9	103,0	72.0	77.5	79.5	0.75	0.82	0.87	25,5	57,0	681	53
				380	3475	20,5	124,7	72.0	77.5	79.5	0.75	0.82	0.87	25,6	57,3		
				220	3465	35,3	215,4	71.0	77.0	78.5	0.79	0.83	0.88	25,8	57,9		
FSME 6/11-3ph.f60.V460-DCX	15	11	20	460	3490	18,0	97,2	72.6	78.1	85.5	0.75	0.81	0.90	30,1	71,0	718	57
				380	3485	21,8	117,7	72.6	78.1	85.5	0.75	0.81	0.90	30,2	71,3		
				220	3475	37,6	203,2	71.6	77.2	84.5	0.75	0.81	0.90	30,4	71,9		
FSME 6/13-3ph.f60.V460-DCX	17,5	13	20	460	3495	23,2	157,0	72.1	77.7	79.9	0.77	0.82	0.87	35,6	85,0	753	60,5
				380	3490	28,1	190,1	72.1	77.7	79.9	0.77	0.82	0.87	35,7	85,3		
				220	3480	48,5	328,3	71.2	77.0	79.0	0.77	0.82	0.87	35,9	85,9		
FSME 6/15-3ph.f60.V460-DCX	20	15	20	460	3485	26,4	195,0	72.3	77.9	80.1	0.77	0.81	0.86	41,1	98,0	798	65,5
				380	3480	32,0	236,1	72.3	77.9	80.1	0.77	0.81	0.86	41,2	98,3		
				220	3470	55,2	407,7	71.5	77.0	79.2	0.77	0.81	0.86	41,4	98,9		
FSME 6/18.5-3ph.f60.V460-DCX	25	18,5	20	460	3490	34,1	265,0	71.8	77.5	80.0	0.74	0.80	0.85	50,5	138,0	858	72,5
				380	3485	41,3	320,8	71.8	77.5	80.0	0.74	0.80	0.85	50,6	138,3		
				220	3475	71,3	554,1	70.9	76.5	79.0	0.74	0.80	0.85	50,8	138,9		
FSME 6/22-3ph.f60.V460-DCX	30	22	20	460	3485	39,5	300,0	74.4	79.3	81.1	0.75	0.80	0.86	60,2	157,0	898	75,5
				380	3480	47,8	363,2	74.4	79.3	81.1	0.75	0.80	0.86	60,3	157,3		
				220	3470	82,6	627,3	73.4	79.3	80.1	0.75	0.80	0.86	60,5	157,9		
FSME 6/26.5-3ph.f60.V460-DCX	35	26,5	26	460	3480	47,1	363,0	74.8	79.7	81.5	0.74	0.80	0.87	72,5	193,0	983	88
				380	3475	57,0	439,4	74.8	79.7	81.5	0.74	0.80	0.87	72,6	193,3		
				220	3465	98,5	759,0	73.8	78.8	80.5	0.74	0.80	0.87	72,8	193,9		
FSME 6/30-3ph.f60.V460-DCX	40	30	26,5	460	3490	55,6	444,0	73.1	78.4	80.7	0.74	0.80	0.84	81,6	240,0	1063	92
				380	3485	67,3	537,5	73.1	78.4	80.7	0.74	0.80	0.84	81,7	240,3		
				220	3475	116,3	928,4	72.2	77.5	79.8	0.74	0.80	0.84	81,9	240,9		
FSME 6/37-3ph.f60.V460-DCX	50	37	26,5	460	3480	69,0	516,0	73.4	78.6	80.8	0.70	0.78	0.83	100,7	249,0	1198	95
				380	3475	83,5	624,6	73.4	78.6	80.8	0.70	0.78	0.83	100,8	249,3		
				220	3465	144,3	1078,9	73.5	77.7	79.9	0.70	0.78	0.83	101,0	249,9		
FSME 6/45-3ph.f60.V460-DCX	60	45	26,5	460	3480	81,0	559,0	75.4	80.1	81.9	0.73	0.80	0.85	123,5	286,0	1273	98
				380	3475	98,1	676,7	75.4	80.1	81.9	0.73	0.80	0.85	123,6	286,3		
				220	3465	169,4	1168,8	74.2	70.1	81.0	0.73	0.80	0.85	123,8	286,9		



# FSME 6 (3ph-60 Hz)

Motor Power Range **5,5 HP - 60 HP**

Thrust Load Capacity **5,5 HP - 30 HP = 20,0 kN**  
**35.0 HP - 60 HP = 26.5 kN**

Outside Diameter **142 mm**

Flange Standard **6" NEMA Standard**

*Due to continuous improvement in design we reserve the right to amend specifications or data without prior notice.*



Type	P <sub>N</sub>		Axial Load kN	Voltage V	Full Load		SF 1.15		n <sub>N</sub> rpm	I <sub>A</sub> A	Efficiency (% load)		Cos Φ (% load)		Cable Size mm <sup>2</sup>	Cable Length m	Motor Length mm	Motor Weight Kg
	HP	kW			Amps	Watt	Amps	Watt			sf	fl	sf	fl				
FSME 6/5.5-1PH.F60.V230-DCX	7,5	5,5	20	230	Y36.8 B34.6 R5.5	7500	8600	8780	3445	171	73	73	0,89	0,89	3x6	4	598	43
FSME 6/7.5-1PH.F60.V230-DCX	10	7,5	20	230	Y45.2 B40.6 R9.5	9800	11200	11500	3450	209	75	76	0,94	0,95	3x6	4	653	48
FSME 6/11-1PH.F60.V230-DCX	12,5	11	20	230	Y62.4 B51.8 R17.5	13900	15900	16200	3460	305	78	79	0,96	0,97	3x10	4	718	55

**LEAD CABLE CONNECTION INSTRUCTIONS**  
(For 6" Single Phase (60Hz / 7,5 HP / 10 HP / 15HP motors))

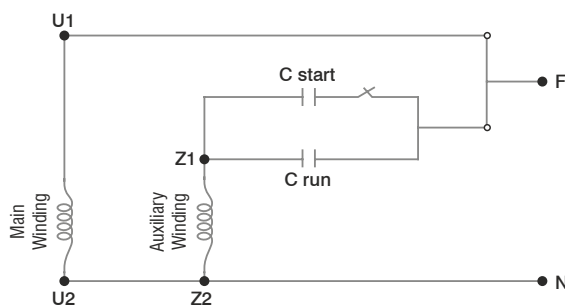

**"US" CONTROL PANEL CONNECTION SCHEMA**

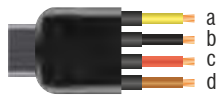

- a) Yellow (Neutral)
- b) Black (Main)
- c) Red (Auxiliary)
- d) Braun (Ground)

Power	Capasitor [uF]	
	C Start	C Run
7,5 Hp	145	130
10 Hp	280	140
15 Hp	300	200

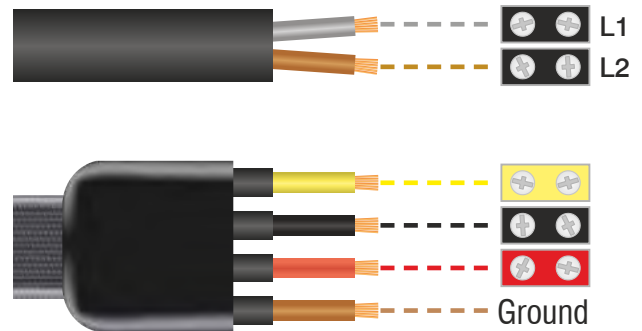

# FSME 6 (1ph-60 Hz)

Motor Power Range	<b>7,5 HP - 15 HP</b>
Thrust Load Capacity	<b>20,0 kN</b>
Outside Diameter	<b>142 mm</b>
Flange Standard	<b>6" NEMA Standard</b>

*Due to continuous improvement in design we reserve the right to amend specifications or data without prior notice.*



**CABLE SELECTION TABLE (DOL)**

HP	Cable Sizes										
	3x1,5	3x2,5	3x4	3x6	3x10	3x16	3x25	3x35	3x50	3x70	3x95
5,5	65	108	172	258	431	689	1.077	1.507	2.153	3.014	4.091
7,5	48	80	129	193	322	515	805	1.127	1.610	2.254	3.059
10	38	64	102	153	256	409	639	894	1.278	1.789	2.428
12,5		52	83	125	209	334	522	730	1.043	1.461	1.982
15		45	72	109	181	289	452	633	904	1.266	1.718
17,5			61	92	153	245	383	536	765	1.071	1.454
20			52	79	131	210	327	458	655	917	1.244
25					106	170	266	372	531	744	1.009
30					90	145	226	316	452	633	859
35					76	122	190	266	380	532	722
40					67	107	168	235	336	470	638
50						89	139	195	279	390	529
60							115	160	229	321	434
70								139	198	278	377
75								131	187	262	356
80								120	172	241	326
90									154	215	292
100									132	192	261
110									127	178	242
125										157	213
150											182
175											155
200											
210											
225											
250											

**CABLE SELECTION TABLE (Wye - Delta)**

HP	Cable Sizes										
	3x1,5	3x2,5	3x4	3x6	3x10	3x16	3x25	3x35	3x50	3x70	3x95
5,5	97	161	258	388	646	1.033	1.615	2.261	3.230	4.521	6.136
7,5	72	121	193	290	483	773	1.207	1.690	2.415	3.381	4.588
10	57	96	153	230	383	613	958	1.342	1.916	2.683	3.641
12,5	47	78	125	188	313	501	783	1.096	1.565	2.191	2.974
15	41	68	109	163	271	434	678	949	1.356	1.899	2.577
17,5	34	57	92	138	230	367	574	803	1.148	1.607	2.181
20	29	49	79	118	196	314	491	688	982	1.375	1.867
25		40	64	96	159	255	398	558	797	1.115	1.514
30			54	81	136	217	339	475	678	949	1.288
35			46	68	114	182	285	399	570	798	1.083
40				60	101	161	252	352	503	705	956
50					84	134	209	293	418	585	794
60					69	110	172	241	344	481	653
70					59	95	149	208	297	416	565
75						90	141	197	281	394	534
80						82	129	180	258	361	490
90						74	115	162	231	323	439
100							103	144	206	289	392
110							95	134	191	267	363
125								118	168	235	319
150								101	144	201	273
175									123	172	233
200										152	207
210										145	196
225										136	184
250											164



## Other Features

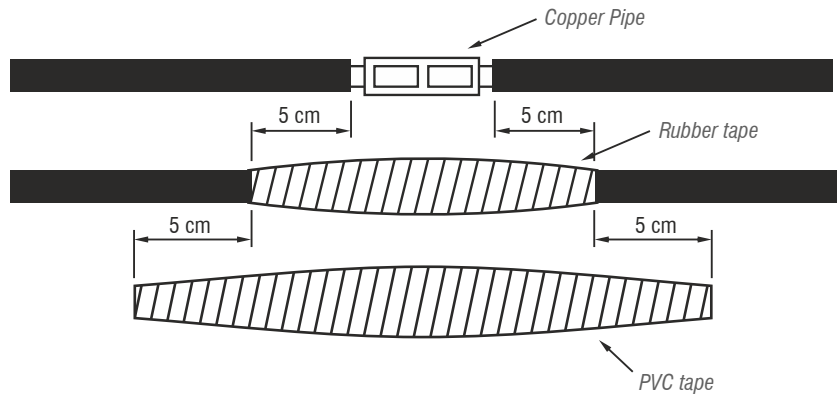

### Power Cable Connection

Connection of the power cable that will be used along the well and until the control panel with the power cable on the motor must be done very carefully and by the professionals only. Unless the insulation after the connection is well done, short circuit might happen when the connection area is in the water.

Insulation of each cable should be stripped only as far as necessary to provide room for a stake type connector. Each individual joint should be taped with pvc tape, using two layers by wrapping tightly for eliminating airspaces as much as possible.

Total thickness of tape should be no less than the thickness of the cable insulation in order to prevent the smashing of the cables when the pump is lowered in the well.

### Use Cooling Jacket

Cooling of submersible motors is provided with the flow of the water around it. That's why water flow around motors has vital importance during submersible pump installation. This flow rate depends on diameter and power of motor.

Most important factor of submersible motors' long service life is that the motor has to be cooled well. Required flow velocity around the motor is given in the table below for motors being cooled well enough.

If the motor will be installed in an open body of water (i.e pool) or diameter of the well is much bigger than the diameter of the motor, Flow Inducer Sleeve must be used to provide the flow velocities that are given in the table below, around the motor.

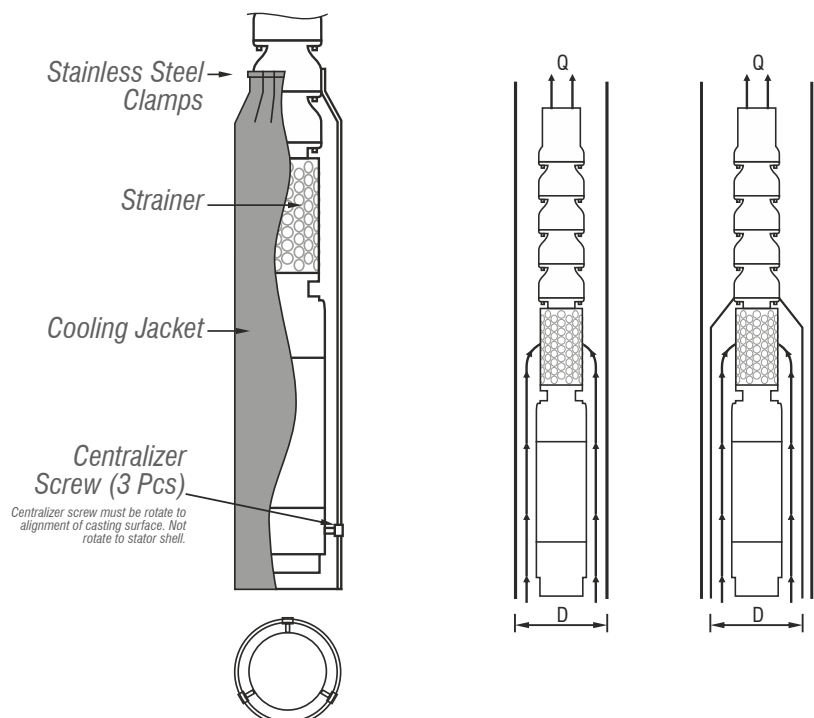



## Insulation Resistance Test

All Dynapumps motors are applied insulation test under 3.000 V before shipment. Motors which have at least 2.000 megaohm test result are shipped. Insulation test results should be controlled before the installation and after connecting power cables as it is explained below. Meger tester's one probe should be touched to motor body and other probe should be touched to tip of each power cable to measure the insulation of each phase. If there is any short circuit in a phase, insulation value is 0 megaohm.

Under the normal operating conditions, a motor inside the well should have 2 megaohm insulation resistance. When the insulation resistance drops under 0.5 megaohm, there might be a insulation problem in winding. Test voltage should be at least 500 V DC.

After extending power cables with a joint, same test procedures should be also applied for insulation control while power cables are inside water. If insulation test result for any winding is lower than 100 megaohm, cable joint should be done again.



## Use Frequency Convertor and Soft Starter

These points listed below should be taken into consideration while operating submersible motors with frequency convertor and soft starter.

- ▶ Needed precautions should have been taken to protect your frequency convertor from voltage fluctuations.
- ▶ Flow rate around motor must be at least 0,15 m/s. If flow rate is not enough, flow inducer sleeve must be used to provide the needed flow rate.
- ▶ In systems which are operated by frequency convertor and soft starter, motor selection should be done as choosing next higher motor rate for pumps will provide long service life for motors.
- ▶ Motors should be operated between 30-50 Hz with frequency convertors. As the protective water layer can't be formed on thrust bearing at the lower frequencies, motor would get damaged.
- ▶ Dual slope frequency convertors should be used while using soft starter too.



## Voltage Drop and Cable Power Loss

To determine the cable section it should be considered that the voltage drop must not exceed 3%. The formulas used for voltage drop calculation are given below.

Direct starter (1 cable)	▶	$U_v = \frac{3,1 \times L \times I \times \cos\varphi}{q \times U}$	$q = \frac{3,1 \times L \times I \times \cos\varphi}{U_v \% \times U}$
Direct starter (2 cables in parallel)	▶	$U_v = \frac{1,55 \times L \times I \times \cos\varphi}{q \times U}$	$q = \frac{1,55 \times L \times I \times \cos\varphi}{U_v \% \times U}$
Star-delta starter	▶	$U_v = \frac{2,1 \times L \times I \times \cos\varphi}{q \times U}$	$q = \frac{2,1 \times L \times I \times \cos\varphi}{U_v \% \times U}$

L : Cable length (m)  
I : Current at nominal voltage (A)  
q : Conductor section (mm<sup>2</sup>)  
cosφ : Power factor  
P<sub>v</sub> : Power loss (%)  
U<sub>v</sub> : Voltage drop (%)  
U : Nominal voltage (V)

The power loss along the feeling cable has to be calculated adjacent to:

$$P_v = \frac{U_v}{\cos^2\varphi}$$



Other Features



### Energy Connection Schema

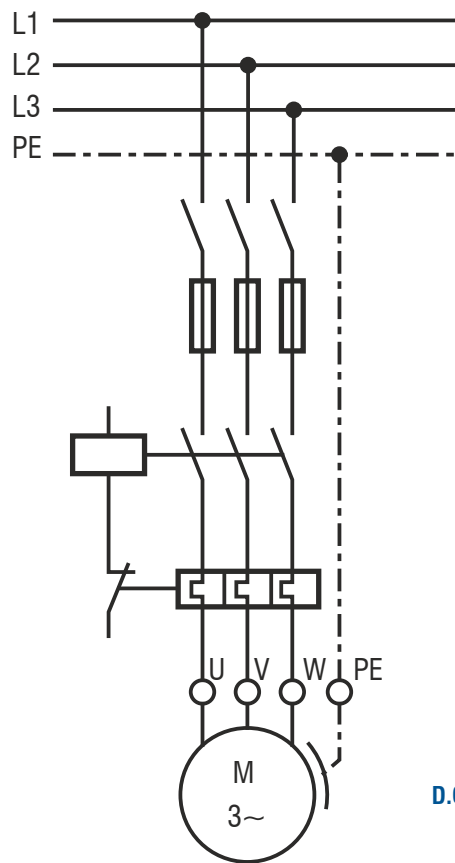

D.O.L Connection

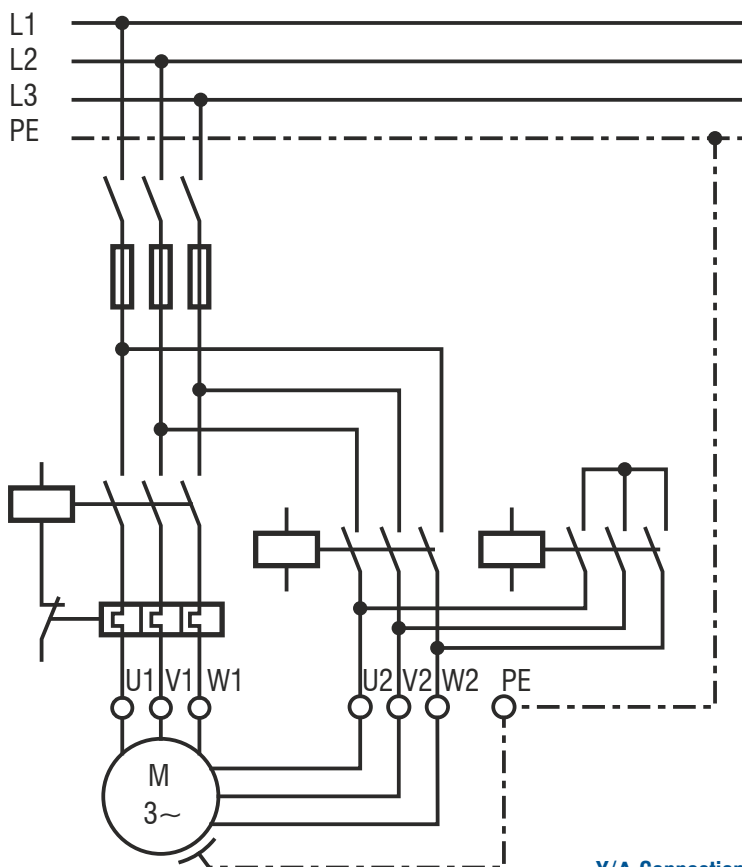

Y/Δ Connection

## Trouble Shooting

### Motor Does Not Start

Possible Cause	Remedy
No power or incorrect voltage	Check voltage at lines. Contact power company if voltage is incorrect
Fuses blown or circuit breakers tripped	Replace with proper fuse or reset circuit breakers
Control box malfunction	Repair or replace
Defective wiring	Correct faulty wiring or connections
Bound pump	Pull pump and correct problem. Run new installation until the water cleans
Defective cable or motor	Repair or replace

### Motor Starts Too Often

Possible Cause	Remedy
Check valve stuck open	Replace if defective
Waterlogged tank	Repair or replace
Lenk in system	Replace damaged pipes or repair leaks

### Motor Runs Continuously

Possible Cause	Remedy
Low water level in well	Throttle pump outlet or reset pump to lower level. Do not lower if sand may clog pump
Worn pump	Pull pump and replace worn parts
Loose coupling or broken motor shaft	Replace worn or damaged parts
Pump screen blocked	Clean screen and rest pump depth
Check valve stuck closed	Replace if defective
Control box malfunction	Repair or replace

### Motor Runs But Overload Protector Trips

Possible Cause	Remedy
Incorrect voltage	Contact power company if voltage is incorrect
Overheated protectors	Shade box, provide ventilation or move box away from source
Defective control box	Repair or replace
Defective motor or cable	Repair or replace
Worn pump or motor	Replace pump and/or motor



# Dynapumps

MORE THAN JUST PUMPS

## **Santiago**

Nueva Tajamar 481,  
Torre Norte, WTC, Oficina 2004  
Las Condes  
Santiago - Chile

## **Concepción**

Camino Los Carros 1955  
Bodega 10, Módulo 2  
Megacentro Los Carros  
Concepción - Chile

Dynapumps Offices Australia & Chile  
[chile@dynapumps.com.au](mailto:chile@dynapumps.com.au)

[www.dynapumps.com.au](http://www.dynapumps.com.au)